

User's Manual

Motor soft starters

SKTR2 Series

Built-in Bypass Motor Soft Starter

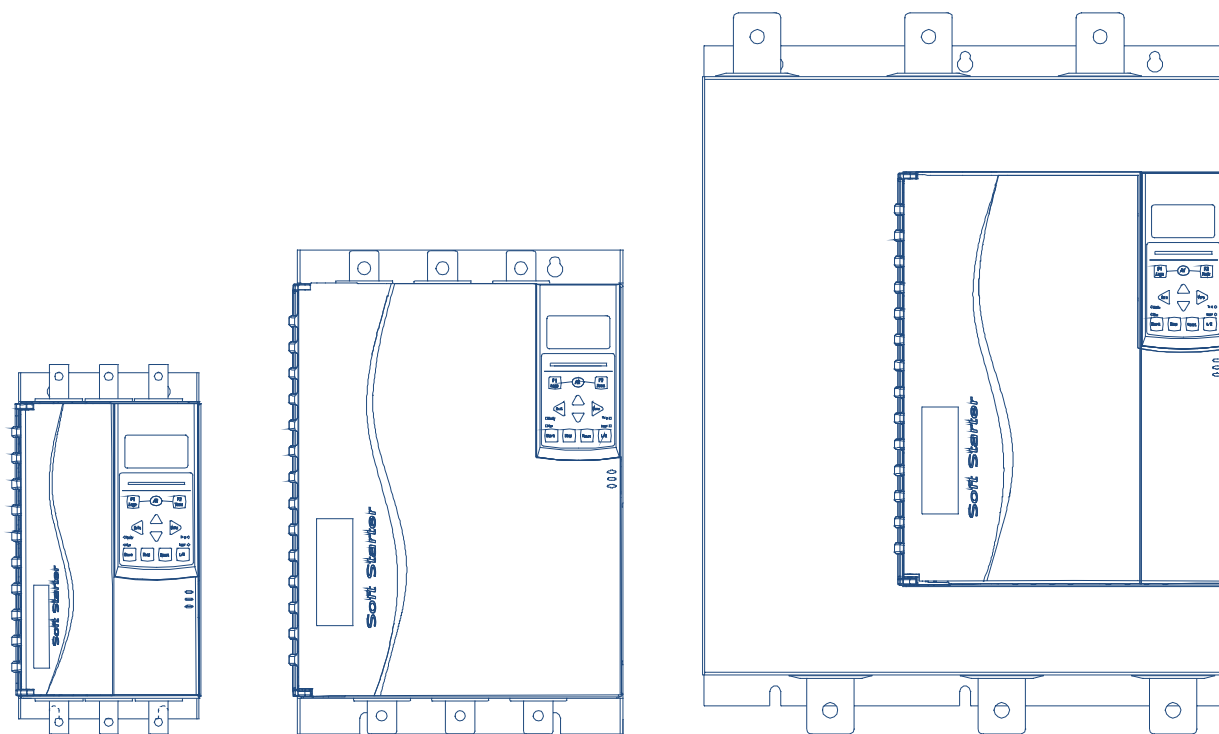

Chapter 1 Caution Statement	01
1.1 Electric Shock Hazard	01
1.2 Disposal Instructions	02
Section 2 Introduction	03
2.1 Feature List	03
Chapter 3 Basic Settings	04
3.1 Setting procedure summary	04
3.2 Testing Equipment Installation	04
3.3 Simulation Tool	04
Chapter 4 Installation	05
4.1 Physical Installation	05
4.2 Control Terminal	05
4.3 Control Voltage	05
4.4 Control Cable	06
4.5 Relay Output	06
4.6 Motor Thermistor	06
4.7 Earthing Terminal	07
4.8 Power Supply Input And Output Configuration	07
4.9 Power Connection	08
4.10 Principle Chart	09
Chapter 5 Power Supply Circuit	10
5.1 Electric Motor Connection	10
5.2 Bypass Contactor	12
5.3 Main Contactor	12
5.4 Circuit Breaker	12
5.5 Power Factor Correction	12
Chapter 6 Operation Board And Feedback	13
6.1 Operation Panel	13
6.2 Display	14
Chapter 7 Repairing Tool	16
7.1 Test Device Installation	16
7.2 Degug Menu	16
7.3 Log Menu	19
Chapter 8 Operation	21
8.1 Command Priority	21
8.2 Start, Stop and Reset Commands	21
8.3 Soft Start Method	21
8.4 Stop Method	24
8.5 Jog Operation	26
8.6 Working With Triangle Connection Method	27

Chapter 9 Programming Menu	28
9.1 Programming Menu	28
9.2 Parameter Write Protection	28
9.3 Access Password	29
9.4 Quick Setup	29
9.5 Standard Menu	30
9.6 Extended Menu	31
9.7 Load / Save Settings	35
9.8 Parameter Description	35
Chapter 10 Application Examples	51
10.1 Installation With Main Contactor	51
10.2 Installation With External Bypass Contactor	52
10.3 Emergency Operation	53
10.4 Auxiliary Trip Circuit	54
10.5 DC Braking With External Zero Speed Sensor	55
10.6 Soft Braking	56
10.7 Two-speed Motor	57
10.8 Slip Ring Motor	58
Chapter 11 Fault Resolution	60
11.1 Protection Response	60
11.2 Trip Message	60
11.3 General faults	64
Chapter 12 Appendix	66
12.1 Specifications	66
12.2 Parameter Value	70
Chapter 13 MODBUS user manual	
13.1 Important usage information	74
13.2 Setting	74
13.3 Modbus function	74
13.4 Modbus Register	75
13.5 Trip code	78
13.6 Internal failure x	79
13.7 Examples	80
13.8 Modbus error code	81
13.9 Modbus control via remote control	81
13.10 Grounding and shielding	81
13.11 RS-485 Data cable connection	82
13.12 RS-485 network connection specification of remote control	82

Section 1 Caution Statements



The use of this symbol in this manual reminds the reader to pay special attention to special precautions regarding the installation and operation of the equipment.

Caution Statements cannot cover every potential cause of equipment damage but can highlight common causes of damage. It is the installer's responsibility to read and understand all instructions in this manual prior to installing, operating or maintaining the soft starter, to follow good electrical practice including applying appropriate personal protective equipment and to seek advice before operating this equipment in a manner other than as described in this manual.



NOTE

The user cannot repair the soft starter. The soft starter should only be repaired by authorized service personnel. Unauthorized modification of the starter will void the product warranty.

1.1 Electrical Shock Risk

The voltages present in the following locations can cause severe electric shock and may be lethal:

- AC supply cables and connections
- Output cables and connections
- Many internal parts of the starter, and external option units

The AC supply must be disconnected from the starter using an approved isolation device before any cover is removed from the starter or before any servicing work is performed.



WARNING DANGER OF ELECTRIC SHOCK

132kW and above: As long as the power supply voltage is connected (including when the starter trips or waits for a command), the bus and radiator must be regarded as charged.



SHORT CIRCUIT

It cannot prevent short circuit. After severe overload or short circuit occurs, the operation of soft start should be fully tested by an authorized service agent.



GROUNDING AND BRANCH CIRCUIT PROTECTION

It is the responsibility of the user or person installing the soft starter to provide proper grounding and branch circuit protection according to local electrical safety codes.



FOR YOUR SAFETY

- The STOP function of the soft starter does not isolate dangerous voltages from the output of the starter. The soft starter must be disconnected by an approved electrical isolation device before accessing electrical connections.
- Soft starter protection features apply to motor protection only. It is the user's responsibility to ensure safety of personnel operating machinery.
- In some installations, accidental starts may pose an increased risk to safety of personnel or damage to the machines being driven. In such cases, it is recommended that the power supply to the soft starter is fitted with an isolating switch and a circuit-breaking device (eg power contactor) controllable through an external safety system (eg emergency stop, fault detector).
- The soft starter has built-in protections which can trip the starter in the event of faults and thus stop the motor. Voltage fluctuations, power cuts and motor jams may also cause the motor to trip.
- There is a possibility of the motor restarting after the causes of shutdown are rectified, which may be dangerous for certain machines or installations. In such cases, it is essential that appropriate arrangements are made against restarting after unscheduled stops of the motor.
- The soft starter is a component designed for integration within an electrical system; it is therefore the responsibility of the system designer/user to ensure the system is safe and designed to comply with relevant local safety standards.

AuCom cannot be held accountable for any damages incurred if the above recommendations are not complied with.



AUTO- - START

Use the auto-start feature with caution. Read all the notes related to auto-start before operation.

The examples and diagrams in this manual are included solely for illustrative purposes. The information contained in this manual is subject to change at any time and without prior notice. In no event will responsibility or liability be accepted for direct, indirect or consequential damages resulting from the use or application of this equipment.

1.2 Disposal Instructions



Equipment containing electrical components may not be disposed of together with domestic waste.

It must be collected separately as electrical and electronic waste according to local and currently valid legislation.

Our company improving its products it reserves the right to modify or change the specification of its products at anytime without notice. The text, diagrams, images and any other literary or artistic works appearing in this document are protected by copyright. Users may copy some of the material for their personal reference but may not copy or use material for any other purpose without the prior consent of us. our company endeavors to ensure that the information contained in this document including images is correct but does not accept any liability for error, omission or differences with the finished product.

Section 2 Introduction

This soft starter is an advanced digital soft starter solution for motors with power from 11kW to 850kW. Provides a complete set of motor and system protection functions to ensure reliable performance even in the harshest installation environments.

2.1 Feature List

Optional soft start curve

- Adaptive control
- Constant current
- Current ramp

Optional soft stop curve

- Taxi stop
- Timed voltage ramp soft stop
- Adaptive control
- Brake

Extended input and output options

- Remote control input
(3 fixed inputs, 2 programmable inputs)
- Relay output
(1 fixed output, 3 programmable outputs)
- Analog output
- Built-in PT100 RTD input
- Optional expansion card

Easy-to-read display shows comprehensive feedback

- Removable operation panel
- Multilingual feedback
- Event record with date and time stamp
- Working counter (starting times, running hours, kilowatt hours)
- Performance monitoring (current, voltage, power factor, kilowatt hours)
- User-programmable monitoring screen

Customizable protection

- Motor overload
- Start-up timeout
- Under current
- Transient overcurrent
- Current imbalance
- Power frequency
- Input trip
- Motor thermistor
- Power circuit
- Phase sequence

Models that meet all your connectivity needs

- 23A-1600A (rated)
- T5, 200VAC-525VAC
- T7, 380VAC-690VAC
- Internal bypass selection
- Star connection or delta connection

Advanced application optional features

- Input / output extension
- RTD and ground fault protection
- DeviceNet, Modbus, Profibus, Ethernet (Ethernet IP, Modbus TCP, Profinet) or USB communication module

Section 3 Basic Setting

3.1 Setting Procedure Summary



Warning: Before cable connection, do not put power supply voltage on soft starter

1. Install soft starter (refer to installation Page 5 to know details)
2. Connect control cable (refer to control terminal Page 5 and control cable page 6)
3. Control voltage applied to soft starter
4. Set up date and time (refer to Page 18)
5. Equipped your application
 1. push MENU, open Menu.
 2. use ▼ to 'fast setting', then push ▼ to open 'fast setting' menu.
 3. Find your application in the list, then push ► to start setting
6. If your application not in list of 'fast setting' list
 1. push ◀ return to 'menu'
 2. use ▼ turn to 'standard menu', then press ►
 3. turn to 'motor data 1' press ►, then press ►, edit parameter 1A motor rated current
 4. set up parameter 1A to match rated current



Attention

regarding to senior application, please refer to extension menu page 33 and parameter instruction page 37.

7. Press ◀ many times, close menu
 8. Optional using built in simulation tool check and control routing connection correct or not
 9. Connect power supply line and soft starter input terminal 1/L1,3/L2,5/L3
- Connect motor cable and soft starter's output 2/T1,4/T2,6/T3

3.2 Testing Equipment Installation

You can test the soft start by connecting it to a small motor. During this test, you can test the soft starter control input and relay output protection settings. This test mode is not suitable for testing soft-start performance or soft-stop performance.

The rated current of the test motor is at least 2% of the minimum rated current of the soft starter (see Minimum and Maximum Current Setting on page 71).



Attention

When testing the soft starter with a small motor, set parameter 1A Motor Rated Current to the minimum allowed value.

3.3 Simulation Tool

Software simulation function allows you test working situation and control circuit under conditions of no connection with soft starter

- **Run simulation**

Simulate the starting, running, and stopping of the motor, and confirm that the soft starter and related equipment are installed correctly. See Run Simulation on page 19 for more information.

- **Protect simulation**

Simulate each protection mode activation, confirming soft starter and relative equipment reaction. refer to simulation protection Page 19

- **Output signal simulation**

Simulate output signal, confirming output and relative control circuit work normally. Refer to signal simulation Page 20

Only when soft starter in condition on ready with control voltage, operation panel in active mode, you can use simulation function



Attention

Input password when using simulation tool
The default access password is 0000

4.4 Control Cable

The soft starter has 3 fixed remote control input. These input shall be controlled by lower rated voltage under condition of small current.

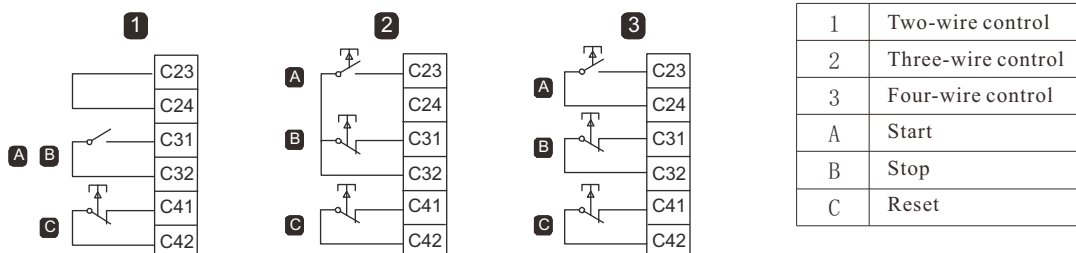

Warning:

Do not apply voltage on control input. These input is 24VDC power supply input, must be controlled by touch point control without electricity.

Connection control input cable must separate with power supply voltage and motor cable

Reset input terminal can be always open or closed. use parameter 6M to select configurations.

4.5 Relay Output

Soft starter has 4 relay output, among them one is fixed output, the other 3 piece is PLC output.

When soft starting complete, carry out output closing (starting current is less than PLC rated current 120%), it is always keeping closing status till stopping running (soft stop or sliding stop)

Refer to 7A~7I settings to decide PLC output action

- If this output terminal use to connect main contactor, when soft starter receive order to starting, active the output terminal. In the process under control of soft starter keep active status all along.
- If this output terminal adapt to trip function, active the output terminal when tripping.
- If the output terminal adapt to indication, active the output terminal when activating specified indication.



Warning:

The switching capacity of a PCB-mounted relay is not suitable for some electronic contactor coils. Consult the contactor manufacturer / supplier to confirm its capacity.

Three additional outputs on the input / output expansion card can be used.

4.6 Motor Thermistor

Connect motor thermistor with soft starter. When thermistor circuit resistor surpass $3.6k\Omega$ or less than 20Ω , the soft starter will trip.

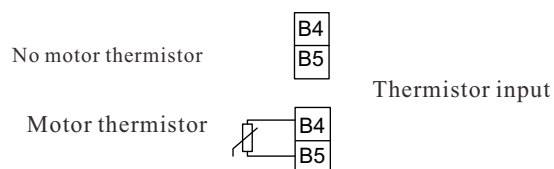

Attention

If no connection between motor thermistor and soft starter, thermistor input terminal B4, B5 shall open circuit. If B4, B5 short circuit, soft starter will trip.

Thermistor shall use shielded cable, it should be separated with ground line and other power supply circuit and control circuit on electricity.

4.7 Earthing Terminal

Earth Terminal locates in back of soft starter.

- 5.5KW~55KW has a earth terminal in input terminal
- 75KW~500KW has 2 earth line terminal,one is in input terminal,the other one is charge of output terminal.

4.8 Power Supply Input And Output Configuration

Connect AC power supply according upside in and output downside

1L1, 3L2, 5L3

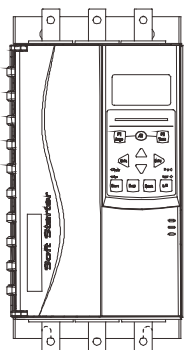

2T1, 4T2, 6T3

1L1, 3L2, 5L3

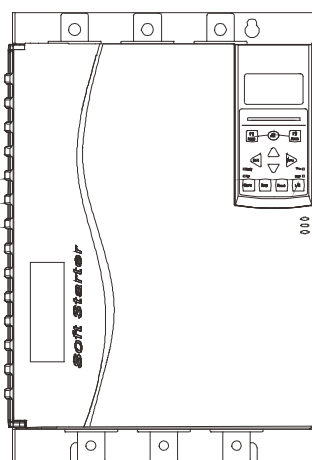

2T1, 4T2, 6T3

1L1, 3L2, 5L3

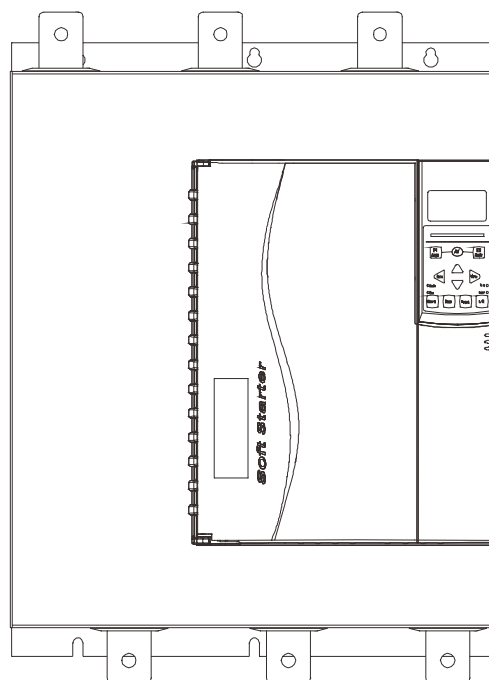

2T1, 4T2, 6T3

4. 9 Power Connection



Attention

Part of soft starter use aluminum generatrix. When connect power supply, we suggest you clean surface thoroughly with appropriate adhesive to resist corrosion

We only use copper strand conductors or solid conductor with rated temperature over 75° C

5.5KW-55KW	75KW-110KW	132KW-320KW

4.10 Principle Chart

Internal bypass type

No internal bypass type

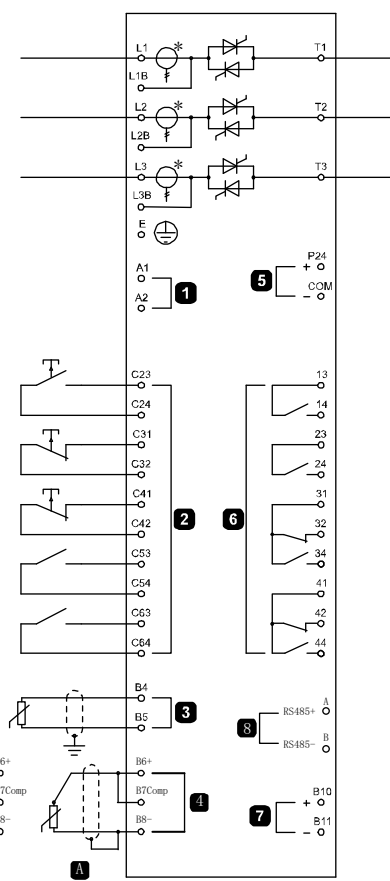
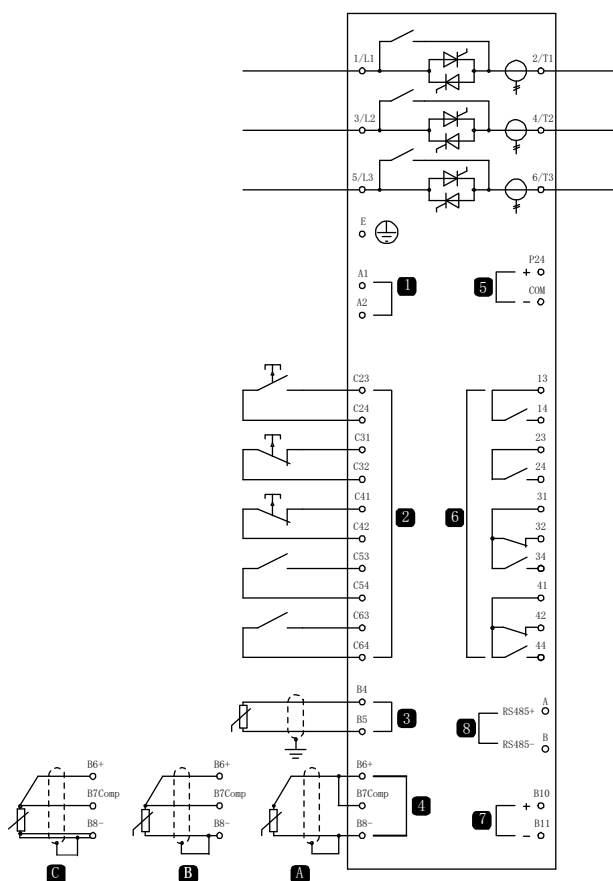

1	Control voltage
2	Remote control input
3	Motor thermistor input
4A	RTD/PT100 input -2 line
4B	RTD/PT100 input -3 line
4C	RTD/PT100 input -4 line
5	24VDC output
6	Relay power
7	Model output simulation
8	RS485 communication output

C23, C24	Start
C31, C32	stop
C41, C42	Reset
C53, C54	PLC input A
C63, C64	PLC input B
13, 14	Relay output A
23, 24	Carrying relay output
31, 32, 34	Relay output B
41, 42, 44	Relay output C

Control Voltage

- (220~440 VAC) A1, A2



Attention

Soft starter current voltage and current transformer locates in output terminal at the output terminal

Chapter 5 Power Supply Circuit

5.1 Electric Motor Connection

Soft Starter can adopt Star Shape connection or triangle connection to connect motor.If we use triangle connection method, use parameter 1A input motor rated current.Soft starter automatically test motor adopt star connection method or triangle connection method for connection and calculate correct triangle connection current.

There are built-in bypass type no need to install outlay bypass contactor.

Internal bypass type:

- 5.5kw、 7.5kw、 11kw、 15kw、 18.5kw、 22kw、 30kw、 37kw
- 45kw、 55kw、 75kw、 90kw、 110kw、 132kw、 160kw、 185kw
- 200kw、 220kw、 250kw、 280kw、 320kw、 350kw、 400kw
- 450kw、 500kw

Star connection, internal bypass

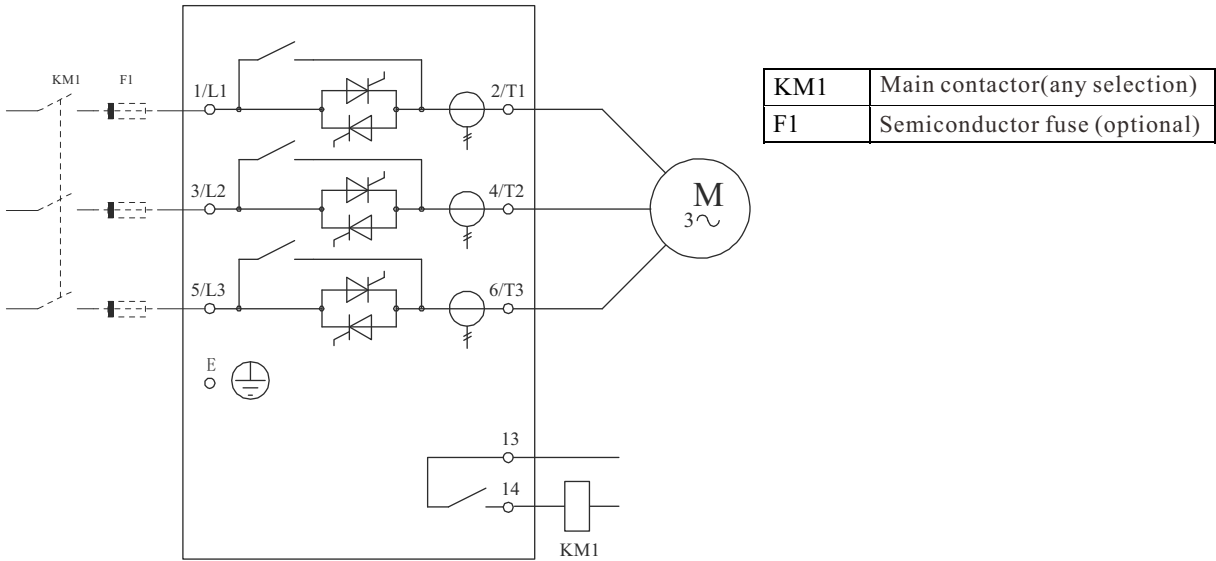

Star shape Connection method,without bypass

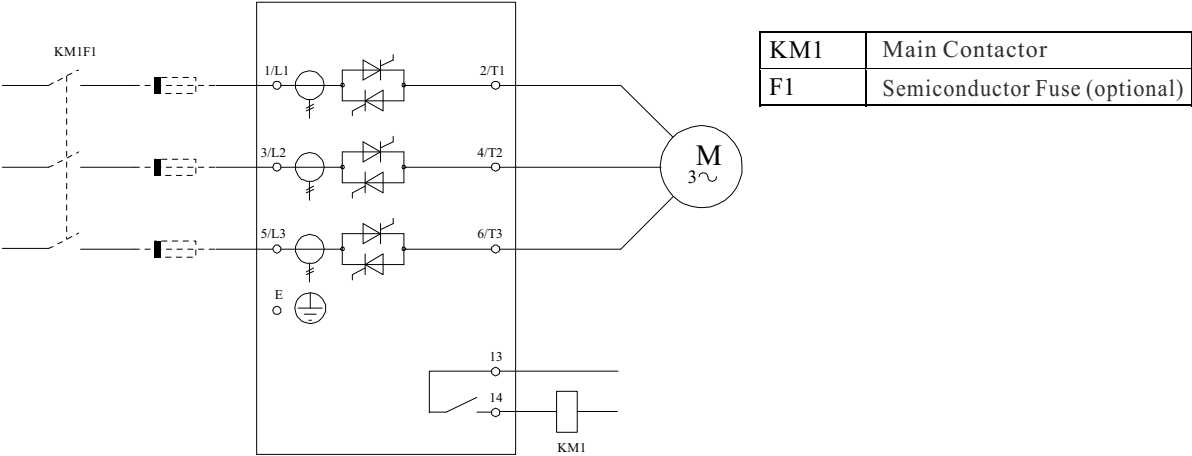

Triangle shape connection method,internal bypass

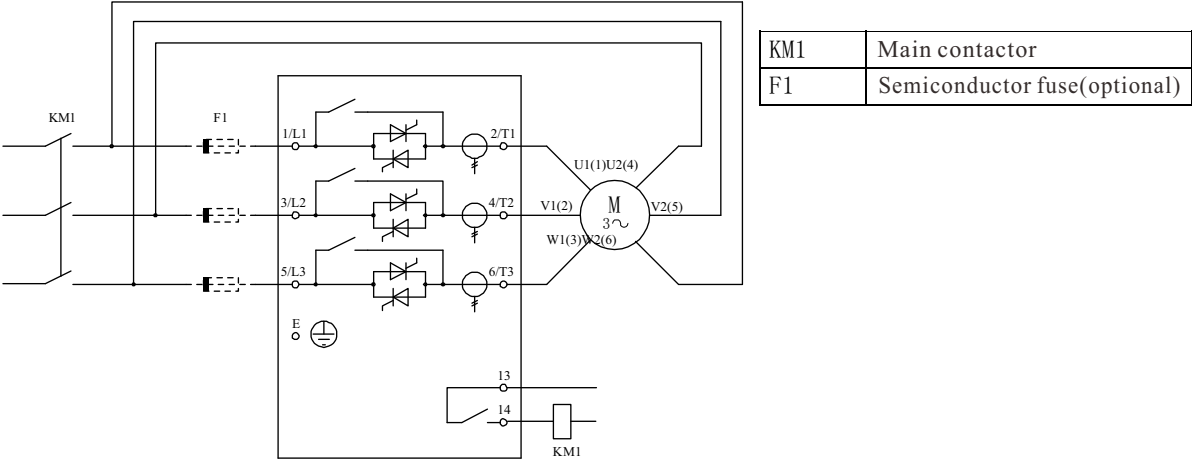

Attention
If adopting triangle connection method connect soft starter,keep install main contractor or Shunt trip circuit breaker.



Attention
If adopt triangle connection method,usd parameter 1A input motor rated current.Soft starter automatically testing motor adopting star connection method or triangle connection method,and Calculate correct triangle connection current.

Triangle connection without bypass

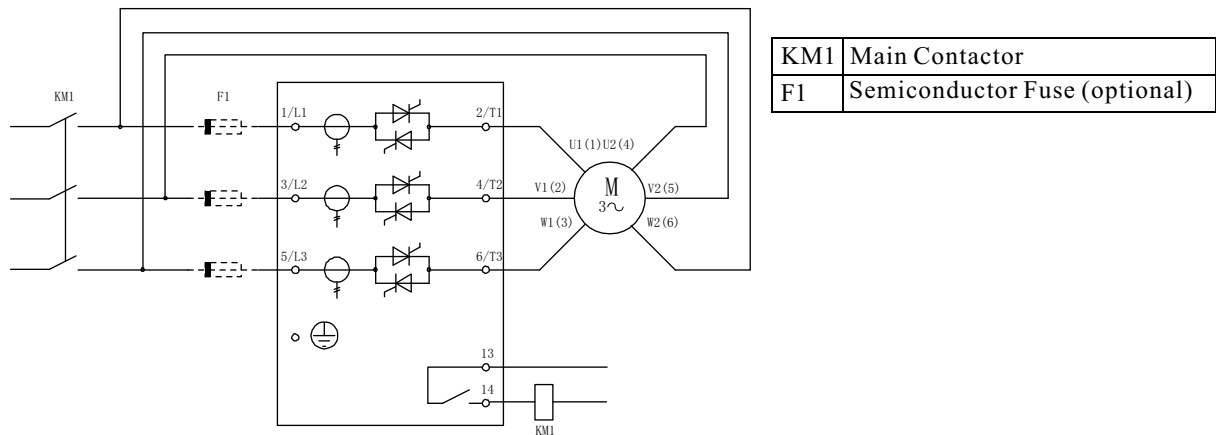

5.2 Bypass Contactor

Some soft starters have built-in bypass, so it is not necessary to install external bypass contactor.

Soft starters without built-in bypass may need to be equipped with external bypass contactors. Select a contactor with AC1 rating greater than or equal to the current rating of the connected motor.

Internal bypass type:

- 5.5kw、7.5kw、11kw、15kw、18.5kw、22kw、30kw、37kw
- 45kw、55kw、75kw、90kw、110kw、132kw、160kw、185kw
- 200kw、220kw、250kw、280kw、320kw、350kw、400kw
- 450kw、500kw

5.3 Main Contactor

If the soft starter is connected to the motor by the triangle connection method, the main contactor must be installed; if the star connection method is adopted, the main contactor can be installed.

Select a contactor with AC3 rating greater than or equal to the current rating of the connected motor.

5.4 Circuit Breaker

It can use Shunt trip circuit breaker, during soft starter tripping disconnect motor circuit, no need to use main contractor

5.5 Power Factor Correction

If use power factor correction, you shall use specified contactor to switching capacitor



Attention

We must connect power factor correction capacitor at input terminal of soft starter.

If we adjust capacitor at output terminal connection power factor correction of soft starter.

Chapter 6 Operation Board And Feedback

6.1 Operation Panel

Operation panel will store copy of soft starter parameter, therefore you can use one operation panel to programme many starters.

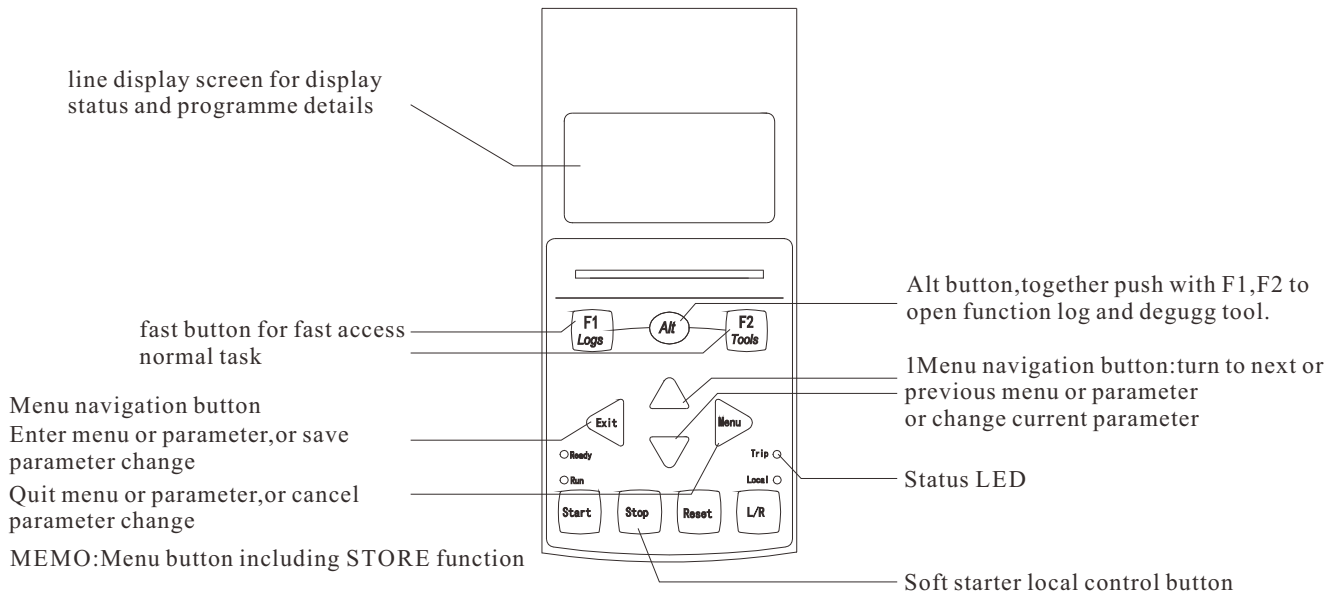

Starter status LED

LED Name	Always ON	Twinkle
Ready	Motor stopped, starter ready for starting	Motor stopped, starter wait, restart delay or motor temperature test
Run	Motor on running status (reach full voltage)	Motor start or stop
Trip	Starter trip	Starter in warming status
Local	Starter in local control status	

If starter in remote control mode, local LED light off
 If all LED off, it indicate soft starter has no control voltage

● Synchronous operation board and starter

When operation board connect with starter, it will keep pace with soft starter with the same settings. If insert different operation board into starters, it will display the confirmation message.

New display detected

Use ▲ up and down ▼ button to choose needed option. Push Menu to accept choice and continue
 If operation board settings have no effect to soft starter, it will load default value

Copy parameter
 Display to starter
 Starter to display

6.2 Display

The operator panel will display various information about the performance of the soft starter. The top half of the screen displays (selected in parameter 8D) real-time current information or real-time motor power information. Use ▲ and ▼ buttons to select the information displayed in the bottom half of the screen.

- soft starter status
- motor temperature
- current
- motor power
- previous starting information
- date and time
- Thyristor conduction



Attention

HERE DISPLAY SCREEN will display default settings.

Soft starter status

Soft starter status screen display starter working status, motor Temperature and motor power detailed information

Be ready
M1 000% 000.0kW

Programmable screen

May equipped clients programmable screen with soft starter Display relative specified applied most important information Use parameter 8E to 8H select which information displayed

Be ready
0000 hrs - - %

Motor temperature

Temperature screen display current using which motor parameter, The temperature of the two motors is shown as a percentage of the total heat capacity. If the soft starter is used only on one motor, the auxiliary motor temperature (M2) always display 0%.

The first group motor setting
► M1 000% M2 000%

Current

The current screen displays the real-time line current for each phase. If RTD/PT100 and the ground fault protection card are installed, the screen also displays the grounding power supply.

Phase current
000.0A 000.0A 000.0A

Motor power

Motor power screen display motor power(KW,HP,KVA) and power factor.

000.0kW 0000HP
0000kVA - . - - pf

Motor power is use power supply according voltage(parameter 8N) to calculate.

Last time starting information

Last time starting information screen display last starting success' detailed information.

- Starting continuous time (seconds)
- Largest starting current(motor rated current percentage)
- Calculate motor temperature rising range

Last starting 010s
350% FLC temp 5%

Date and time

Date/time screen display current system date and time(24 hours format).if you want to know how to set up time and date,refer to page 18.

Function chart

Function chart display real time working character.Use parameter 8I~8L select information need to displayed

000.0A 0-400%

Thyristor conduction bar chart

Thyristor conduction bar chart display each phase conduction level

L1 Conduction

L2 Conduction

L3 Conduction

Chapter 7 Repairing Tool

7.1 Test Device Installation

The soft starter can be connected to a small motor for testing. During this test, the soft starter control input and relay output protection settings can be tested. This test mode is not suitable for testing soft start performance or soft stop performance.

The rated current of the test motor shall be at least 2% of the minimum rated current of the soft starter (see page 71 for minimum current and maximum current settings)



Attention

When testing the starter with a small motor, set the parameter 1A motor rating to the allowable minimum.

7.2 Degug Menu

'test menu' provide access to degugg and testing tool
Press ALT,then press tool,open 'tool'.

Debug Menu Navigation

- Press ▲ or ▼ button and turn to next or last option
- Press ► button to open one option to check
- Press ◀ button to return to upper menu
- Press many times to close ◀ menu

Set up date and time

- 1.Press ALT,then press tool,open 'tool'.
 - 2.Turn to date/time screen
 - 3.Press ► button to enter edit mode
 - 4.Press ► and ◀ botton to selection parts of date and time settings.
 - 5.Press ▲ or ▼ button to modify value
 - 6.Press ► button to save change.the soft starter confirm the modification.
- Press ◀ button to cancel modification.

Simulation tool

Software fax tools allow you to test the operation and control circuit of the soft starter when the soft starter is disconnected from the power supply voltage. There are three simulation modes for soft starters.

- Operation simulation Simulate the start, operation and stop of the motor, and confirm that the soft starter and related equipment are installed correctly.
- Protection simulation Simulate the activation of each protection mechanism and confirm the normal response of soft starter and related equipment.
- Output signal simulation Analog output signal, confirm the output and related control circuit work normally.

The simulation tool can be accessed through the debug menu. The simulation function can only be used when the soft starter is in ready state, with control voltage and the operation board is in active state.



Attention

Simulation tool is protected by access password
Default save password is 0000

Operation Simulation

You can press the EXIT button to finish the simulation at any time.
Using operation simulation

1. press ALT, then press the tool to open the tool.
2. turn to the running simulation and press ► button.
3. press the start button, or activate the input. Soft starter simulation before starting check
Close the main contactor (if installed) and run LED flicker.



Be careful

If the power supply voltage is connected, the error message is displayed.
Disconnect the power supply voltage and continue the next step.

4. Press ► button. Soft starter simulation starts, running LED flicker.
5. Press ► button to simulate the soft starter. Running LED is often bright
without blinking, bypass relay closure.
6. Press the STOP button, or activate the stop input, and the soft starter simulation stops.

Run LED flicker, bypass relay opens

7. Press ► button, ready LED twinkle, main relay open.
8. Press ► to return to the debug menu.

Protection simulation

Protect the activation of each protection mechanism in simulation, confirm the
normal response of soft starter and related equipment.

Using protection simulation

1. press ALT, then press ► tool to open the tool.
2. turn to the protection simulation, press the button.
3. use ▲ and ▼ buttons to select the protection to emulate.
4. press ► button to select the protection selected by simulation.
5. display the screen immediately. The soft starter response depends on the protection settings.
6. use ▲ or ▼ button to choose another simulation, or press ◀ key to exit.

Attention



How to protect the tripping from soft start, then reset before simulating another protection.

If protection setting as "alarm and record" no need to reset.

If protection settings are alarming and log.

Only if press menu store to check the alarm message.

If protection is set to log, the screen does not display any messages,
but adds a record to the log

Running simulation
ready to apply
start signal

Check storage and
continue before running
simulation start

Operation simulation
Be careful!
Power off voltage
Store and continue

Operation simulation
Start X: XX seconds
Store and continue

Operation simulation
Function
Apply stop signal

Operation simulation
Stop X: XX seconds
Store and continue

Operation simulation
Stop it
Store and continue

0.0A

Trip trip
Selected protection

Output signal simulation



The output signal simulates the output signal, confirms that the output and the related control circuit are working properly, and pays attention to setting the output relay as an appropriate function to monitor the operation of the relay if the marking operation (motor temperature and small/large current) is to be tested.

Using output signal simulation

1. press ALT, then press the tool to open the "tools".
2. turn to output signal simulation, press ► button.
3. use ▲ and ▼ buttons to select the function that you want to emulate, then press ► button.
4. use ▲ and ▼ buttons to switch signals.
5. Press ◀ to return to the simulation list.

```
Programmable relay a
OFF
ON
```

Analog output simulation

Analog output simulation ▲ and ▼ button to modify output terminal current

With the current measuring device analog output terminal,

use ▲ and ▼ button to adjust the percentage value displayed on the display.

The current measured by the current measuring device should be the same as the current displayed on the display.

If the input/output expansion card is installed, the operation of the relay outputs D, E, F and analog output B can also be tested by simulation.

```
Analog output A
0%
4.0mA
```

Temperature sensor status

This screen shows the status of the motor thermistor and RTD/PT100.

S = short circuit

H = heat

C=cold

O=open

```
Temperature sensor status
Thermistor: 0
RTD/PT100s: OOOOOOOO
S = Shrt H=Hot C=Cld O=Opn
```

Only if install RTD/PT100 and earth error extension card,you can use RTD/PT100 B~G

Number I/O status

This screen display number input and output current status

The first line of screen display start input,stop input,reset input and programmerable input(A and B,I/O extension card input)

The last line of the screen shows programmable output A, fixed run output, programmable outputs B and C, and output on the expansion card (if installed)

```
Digital I / O status
Input: 011000
Output: 0000100
```

Analog output and input status

This screen shows the analog output and the current state of the input

This screen also shows analog output B if an expansion card is installed

```
Analog I / O status
Input: - - - %
Output a: 04. 0ma
```

Reset heat protection model

The soft starter's advanced thermal protection model software continuously monitors motor performance so that the soft starter can calculate the motor temperature at any time and can be successfully started at any time. If the soft starter is configured for use on two motors, the temperature of each motor is modeled separately.

The thermal protection model of the selected motor can be reset if necessary

1. Press ALT, then press Tools to open Tools.
2. Scroll to the reset thermal protection model and press ► button
3. Use ▼ button to select reset, press stop button to confirm.
4. After resetting the thermal protection model, the screen displays a confirmation message and returns to the previous screen.

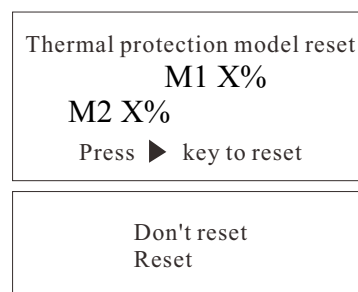

Be careful

Resetting the motor thermal protection model may be detrimental to the life of the motor and should only be used in the event of an emergency.

7.3 Log Menu

The log menu provides information about events, trips, and starter performance. Press ALT, then F1 (log) to open log

Open the event log:

- Press ALT, then press F1 (log) to open 'Log'
- Press ► button to open the log
- Press ▲ and ▼ buttons to scroll through the items in each log
- Press ► arrow button to view log details
- Press ◀ arrow button to return to the previous menu

To close the 'Log Menu', press ◀ arrow multiple times

The log menu can only be opened when viewing the monitor screen

Trip log

The trip log stores details of the eight most recent trips, including the trip date and time, Trip 1 is the most recently stored trip, and Trip 8 is the longest trip.

Turn on the trip log:

1. Press ALT, then press F1 (Log) to open 'Log'.
2. Scroll to the trip log and press ► button
3. Use ▲ and ▼ arrows to select the event you want to view and press ► to right-click to display the details.
4. To close the log and return to the home screen, press ◀ arrow multiple times

Performance counter

The event log stores the details of the 99 latest events (operation, warning and trip) of the starter, with a time stamp, including the date and time of the event. Event 1 is the latest stored event, and event 99 is the longest stored event.

Turn on the trip log:

1. Press ALT, then press F1 (Log) to open 'Log'.
2. Scroll to the trip log and press ► button
3. Use ▲ and ▼ arrows to select the event you want to view and press ► to right-click to display the details.
4. To close the log and return to the home screen, press ◀ arrow multiple times

Performance counter

The performance counter stores the starter operating statistics:

- Running hours (service life and counters since last reset)
- Number of starts (service life and counter after last reset)
- Motor kWh (service life and counter after last reset)
- Reset times of thermal protection model

Only when the parameter write protection (parameter 15b) is set to read / write, can the resettable counter (running hours, starting times and motor KWH) be reset.

View calculator

1. Press ALT, then press F1 (log).
2. Scroll to the counter and press ► button
3. Press ▲ and ▼ buttons to scroll through the counter and press ► button to view the details to the right
4. To reset the counter, press ► button and use ▲ and ▼ buttons to select Reset/No Reset. Press the MENU button to confirm the operation. To turn off the calculator, return to the log menu and press ► arrow key.

Chapter 8 Operation

8.1 Command Priority

The starter disable command takes precedence over any other control command, see parameter 6A Input A Function P43
 The emergency run command gives priority to normal control commands, including the auto start/auto stop command, see parameter 15C Emergency Run on P52.
 The auto start/auto stop command takes precedence over the normal control command (local, remote, or via serial communication). See also 3 Auto Start/Stop P39.

8.2 Start, Stop and Reset Commands

There are three ways to control the soft starter

1. Using the buttons on the control panel
2. Input via remote control
3. Connect via serial communication

The L/R (local/remote) button controls whether the soft starter responds to local control (via the operator panel) or remote control (via remote input).

- When the soft starter is in local control mode, the local LED on the control panel illuminates.
- When the soft starter is in remote control mode, the local LED is off.

Control via serial communication network is always enabled in local control mode, enabling or disabling via serial communication network control (parameter 6R remote communication) in remote control mode, optional communication is required for control over serial communication networks Module.

Always enable the STOP button on the control panel.

Control the motor with a soft starter

To soft start the motor, press the start button on the operator panel or activate the start remote input. The motor will start using the starting mode selected in parameter 2A.

To soft stop the motor, press the stop button on the operator panel, or activate stop remote input. The motor will stop in the stop mode selected in parameter 2H1.

To reset the soft starter trip, press the ESET button on the operator panel. Or activate reset remote input.

To allow the motor to coast to a stop regardless of the setting in parameter 2H stop mode, press the local stop and reset buttons simultaneously.

The soft starter will disconnect the power supply of the motor and open the main contactor to stop the motor sliding.

Auto start / auto stop

The soft starter can also be configured to start or stop automatically. The auto start / auto stop operation can only be used in remote mode. In local mode,

The starter will ignore all auto start / auto stop settings. To configure the auto start / auto stop operation, use parameter 3A ~3D.

8.3 soft start method

Soft starters provide a variety of ways to control motor starting. Each soft start method uses different main control parameters.

Soft start method	Controlled parameter	Performance parameters affected
Timing voltage ramp	Voltage	Starting current, starting torque, acceleration
Constant current	Electric current	Starting torque, acceleration
Torque control	torque	Starting current, accelerating
Adaptive control	accelerate	Starting current, starting torque

The best effect can be achieved by selecting the soft start method which can directly control the most important application parameters. Soft starters are usually used to limit motor starting current or to control load acceleration and / or deceleration. The soft starter can be set to constant current or adaptive control.

Control	Use
Motor Starting Current	Constant Current
Motor / Load Acceleration	Adaptive Control

Constant current

Constant current is the traditional soft start mode, which increases the current from zero to the specified current, and then remains unchanged until the motor accelerates.

Constant current starting is suitable for applications where the starting current must be controlled below a certain level.

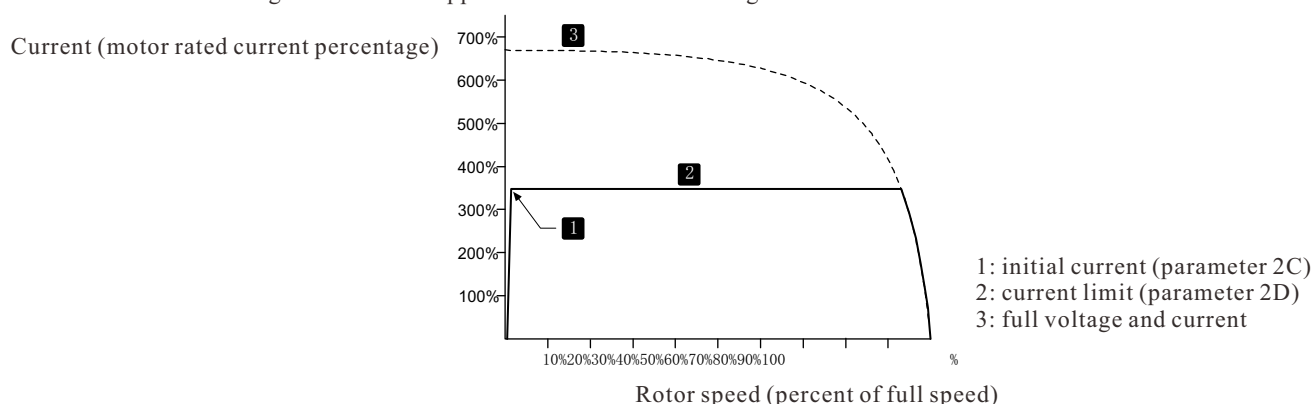

Current slope

The current ramp soft start increases the current from the specified starting current (1) to the maximum limit (3) within the extended period (2).

Current ramp starting can be used for the following applications:

- the load for each start is different (e.g. conveyor belt for heavy load start or no load start).

Set the initial current (parameter 2C) to the light load starting current of the motor, and

The current limit (parameter 2D) is set to the motor heavy load starting current.

- the load is easy to unload, but the starting time must be extended (e.g. centrifugal pumps that need to slowly build up line pressure).
- Limited power supplies (e.g. generator sets) and slow load loading allow more time for the power supply to respond.

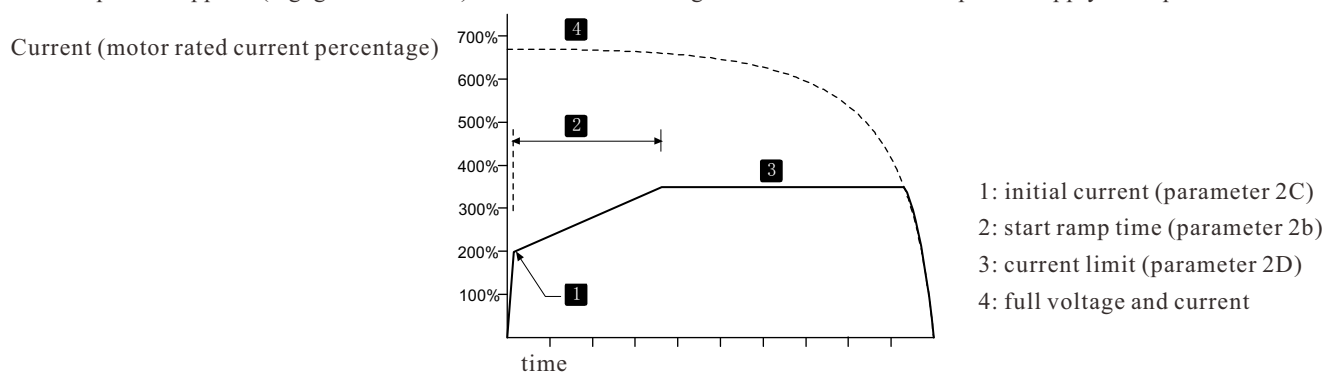

Adaptive start control

In the soft start mode of adaptive control, the soft starter will adjust the current so that the motor can start with the selected acceleration curve within a specified time.



Look out

The speed of adaptive control starting motor can not be faster than that of direct starting mode.

If the starting ramp time (parameter 2b) is shorter than the direct starting time of the motor, the starting current may reach the direct starting current level.

Each application has a specific starting curve based on load characteristics and motor characteristics. Adaptive control provides three different starting curves, which can meet different application requirements. The selection of the curve matching with the application of the inherent curve will help to make the acceleration process smooth in the whole starting time.

If the adaptive control curve with great difference is selected, the control effect of the inherent curve will be greatly affected.

The soft starter monitors the motor performance every time it starts the motor, so as to improve the soft start control in the future.

- adaptive control

Using adaptive control to control the starting performance:

1. Select adaptive control (parameter 2a) on the start mode menu
2. Set the desired starting ramp time (parameter 2b)
3. Select the desired adaptive starting curve (parameter 2e)
4. Set the starting current limit (parameter 2D) large enough to start successfully. The first adaptive control start is constant current start. In this way, the soft starter can understand the characteristics of the connected motor. In the subsequent adaptive control starting process, the soft starter uses this motor data.

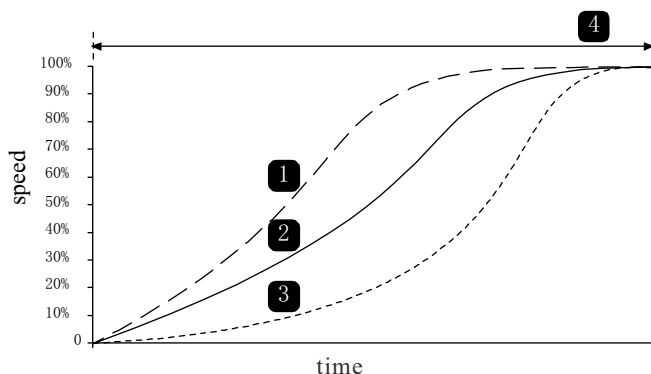

Adaptive starting curve (parameter 2e)
 1. early acceleration.
 2. Constant acceleration
 3. post acceleration
 4. Start ramp time (parameter 2b)



Be careful

Adaptive control controls the load according to the programmed curve. The starting current varies with the selected acceleration curve and the set starting time. .

If a motor connected to a soft starter programmed with adaptive control to start or stop is replaced, or the starter is tested on a different motor before it is actually installed, the starter must learn the characteristics of the new motor. If parameter 1A motor rated current or parameter 2K adaptive control gain is changed, the motor characteristics will be understood again automatically.

- How to select the starting curve of adaptive control
 The best curve depends on the exact details of each application. Some loads such as submersible pumps should not be operated at low speed. The early acceleration curve increases the speed rapidly in the starting process, and then controls the acceleration in the remaining starting time.



Look out

Adaptive control can control the speed curve of the motor in the programmed time range. This may result in a larger current than traditional control methods.

- fine tuning adaptive control
 If the motor starts or stops unevenly, adjust the adaptive control gain (parameter 2K). The gain setting determines how much gain the soft starter will adjust at the next adaptive control start and stop based on the information from the last start. The gain setting affects both starting and stopping performance.
- If the motor accelerates rapidly at the end of starting or decelerates rapidly at the end of stopping, increase the gain setting by 5% 10%.
- If the motor speed fluctuates during start or stop, slightly decrease the gain setting.



Be careful

Reset the adaptive control learning record of the starter when changing the gain setting. After changing the gain, start with a constant current for the first time.

Jump start

Jump start provides additional torque for a short time at the start of starting, which can be used with current ramp starting or constant current starting.

Jump starting helps to start loads that require a minimum starting torque but are easy to accelerate later (e.g. flywheel loads such as calendars).

Current (motor rated current percentage)

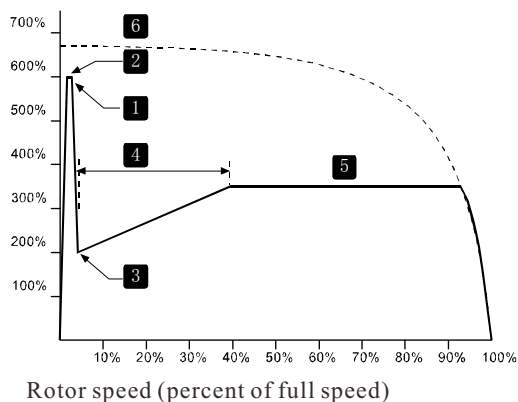

1: jump start amplitude (parameter 2G)
 2: jump start time (parameter 2f)
 3: initial current (parameter 2C)
 4: start ramp time (parameter 2b)
 5: current limit (parameter 2D)
 6: full voltage and current

8.4 Stop Method

The soft starter provides a variety of ways to control the motor stop.

Stopping method	Performance results
Taxi stop	Natural load stop
TVR soft stop	Extend stop time
adaptive control	Extend the stop time according to the selected deceleration curve
braking	Reduce stop time

Soft starters are commonly used in pumping applications to eliminate the destructive effect of water hammer. Adaptive control should be the preferred stop method for these applications.

Taxi stop

The sliding stop makes the motor slow down at the natural speed and is not controlled by the soft starter. The time required to stop depends on the type of load.

Timing voltage ramp soft stop

The timing voltage ramp gradually reduces the motor voltage over a specified period of time. After stopping the ramp, the load may continue to run.

Timed voltage ramp stop can be used for applications requiring extended stop times or to avoid transient power supply of the generator set.

Voltage (percent of full voltage)

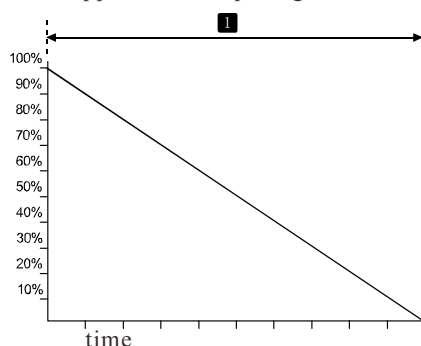

1: stop time (parameter 2I)

Adaptive stop control

In the soft stop mode of adaptive control, the soft starter controls the current to make the motor stop using the selected deceleration curve within the specified time. Adaptive control can be used to extend the stop time of low inertia load. Each application has a specific stop curve based on load characteristics and motor characteristics. Adaptive control provides three different stop curves. Select the adaptive control curve that can best meet the application requirements.



Be careful

The adaptive control does not let the motor decelerate rapidly, and the motor stop speed is not faster than the sliding stop. To shorten the stop time of the large inertia load, use the brake operation.



Look out

Adaptive control can control the speed curve of the motor in the programmed time range. This may result in a larger current than traditional control methods.

adaptive control

Use adaptive control to control stop performance:

1. Select adaptive control (parameter 2H) on the stop mode menu
2. Set the desired stop time (parameter 2I)
3. Select the desired adaptive stop curve (parameter 2J)

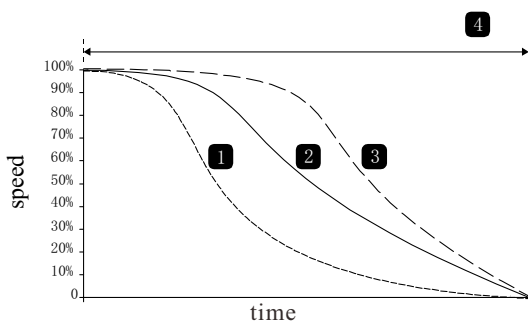

Adaptive control stop curve (parameter 2J):

1. Early slowdown
2. Constant deceleration
3. After deceleration
4. Stop time (parameter 2I)

The first adaptive control stop is the normal soft stop. In this way, the soft starter can understand the characteristics of the connected motor. This motor data is used by the soft starter during subsequent adaptive control stops.



Be careful

Adaptive control controls the load according to the programmed curve. The stop current varies with the selected deceleration curve and stop time.

If a motor connected to a soft starter programmed with adaptive control to start or stop is replaced, or the starter is tested on a different motor before it is actually installed, the starter must learn the characteristics of the new motor. If parameter 1A motor rated current or parameter 2K adaptive control gain is changed, the soft starter automatically re-understands the motor characteristics.

● **Pump stop**

The hydraulic characteristics of pumping system are quite different. This difference means that different deceleration curves and stop times are used for different applications. The following table provides the selection principles for the adaptive control deceleration curve, but we recommend that you test three curves to determine the best curve for the application.

Adaptive stop curve	Application
After deceleration	Even if the motor / water pump speed decreases a little, it will lead to a high head system with fast switching of forward flow and reverse flow.
Constant deceleration	The application of medium and low head and large flow with large liquid momentum.
Early deceleration	An open pumping system in which the liquid must return through the pump but the pump does not reverse.

Braking

Braking can shorten the motor stop time.

During braking, the motor can be heard to make more noise. This is a normal motor braking phenomenon.

After selecting the brake, the soft starter will use dc injection method to slow down the motor.

Soft starter brake:

- DC braking contactor is not required.
- control all three phases to evenly distribute the braking current and corresponding heating in the motor.

Look out



If the braking torque is set too high, the motor stops before the end of the braking time, and the motor generates too much heat, which may cause motor damage. Brake torque must be carefully configured to ensure safe operation of the starter and motor.

When the motor stops, the peak current of the direct starting motor will appear due to too much braking torque setting. Make sure that the fuse installed in the branch circuit of the motor is correctly selected.



Look out

The brake operation makes the heating speed of the motor faster than that calculated by the thermal protection model of the motor.

If brake operation is used, install a motor thermistor or set a restart delay long enough (parameter 4m).

Braking is divided into two stages:

- pre braking: moderate braking to reduce the motor speed to the point where full braking can be successfully carried out (about 70% of the speed).
- full braking: provide the maximum braking torque, but the effect is not good when the speed exceeds about 70%.

Equipped with soft starter for braking operation:

1. Set the desired stop time length (1) for parameter 2I. This is the total braking time, which must be set to be more than the braking time (parameter 2m) For a long time, in order to reduce the motor speed to about 70% before braking. If the stop time is too short and the motor fails to brake successfully, the motor will Taxi stop.
2. Set the braking time (parameter 2m) to about a quarter of the programmed stop time. This is the time of the full braking period (2).
3. Adjust the braking torque (parameter 2L) to achieve the desired stopping performance. If the setting is too small, the motor can not stop stably, but will be closed during the braking period After bunching, taxiing stops.

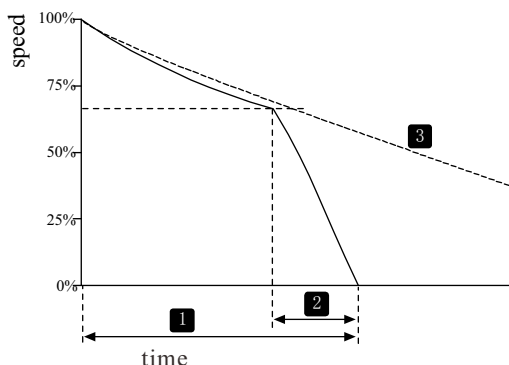

- 1: stop time (parameter 2i)
- 2: braking time (parameter 2m)
- 3: taxi stop time



Be careful

When using DC braking, the power supply and soft starter (input terminals L1, L2, L3) must be connected in positive phase sequence, and the parameter 4G phase sequence must be set to positive.



Be careful

If the load may change during braking, install a zero speed sensor to ensure that the soft starter stops DC braking when the motor stops.

This can avoid unnecessary heating of the motor.

For details on how to use a soft starter with an external speed sensor (for example, in applications where the load changes during braking), see DC braking with an external zero speed sensor on page 57.

8.5 Jog Operation

Jog to slow down the motor in order to adjust the load or assist in maintenance. The motor can either jog forward or jog reverse.



Look out

Low speed operation makes the cooling effect of motor decrease, so it is not suitable for continuous operation mode.

Inching operation makes the heating speed of the motor faster than that calculated by the thermal protection model of the motor. If inching operation is used, install - a motor thermistor, or set a restart delay long enough (parameter 4m).



Be careful

Soft start and soft stop cannot be used during inching operation.

Inching is only applicable to group motor. For a detailed understanding of the -- group motor settings and the second group motor settings, refer to the second group motor settings.

For different motor models, the maximum forward inching torque is about 50% - 75% of the rated torque (FLT). The torque of motor reverse inching is about 25% to 50% of rated torque.

Valuepoint 15E the ratio of the torque applied to the motor by the inching torque control to the maximum inching torque of the soft starter.



Be careful

If parameter 15E is set above 50%, shaft vibration may be increased.

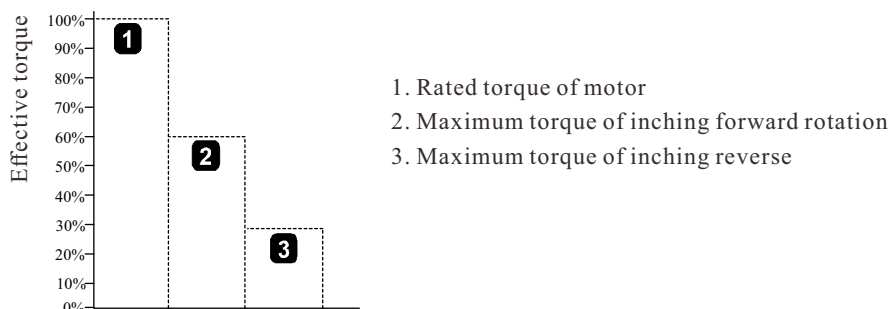

To activate the jog operation, you can use the programmable inputs (see parameters 6a and 6F [only operate in remote control mode]), or you can use the shortcut keys (parameters 8b and 8C).

To stop the jog operation, do one of the following:

- Cancel the jog command.
- Press the stop button on the operator panel.

If the jog command is still valid, start the jog again after the end of the restart delay. During the jog operation, all commands except the above are ignored.

8.6 Working With Triangle Connection Method

The triangle (six wire) connection method does not support adaptive control, inching, braking and two-phase control functions. If these functions are programmed when the starter is connected by the triangle connection method, the control characteristics are as follows:

Adaptive control start	The starter performs a constant current start. .
Adaptive control stop	If the stop time of parameter 2I is set to be greater than 0 s, the starter will perform the soft stop of timing voltage ramp. If parameter 2I is set to 0 seconds, the starter performs a coast down stop.
Point movement	Starter alarm with error message: option not supported.
Braking	The starter performs a coastdown stop.
Two phase control	The starter trips and displays the error message: LX TX short circuit.



Be careful

If the triangle connection method is adopted, the current unbalance protection is the only phase loss protection during operation. Do not disable the current unbalance protection (parameter 4h) when the delta connection method is used.



Be careful

If delta connection method is adopted, input the rated current of motor with parameter 1A. The soft starter automatically detects whether the motor is connected by the star connection method or the triangle connection method, and calculates the correct current of the triangle connection.

Chapter 9 Programming Menu

The programming menu can be accessed at any time, including when the soft starter is running. Any changes to the starting curve take effect immediately.

The programming menu has four submenus:

Quick setup quick setup guides you through how to configure the parameters required for soft starters for common applications. Quickly set up suggestions for each parameter - a value, but you can make more Change these values.

Standard menu

standard menu is convenient for you to access common parameters. You can configure the soft starter according to your own application here.

Extended menu

extended menu is convenient for you to access all programmable parameters of the soft starter, and experienced users can make full use of advanced functions.

Load / save settings

load / save settings allows you to save the current parameter settings to a file, load the parameters in the previously saved file, or reset all parameters to the Default value.

9.1 Programming Menu

You can use the programming menu to view and change programmable parameters that control how the soft starter works.

While viewing the monitoring screen, press the menu button to open the programming menu.

Browse "Programming Menu":

- Press ▲ or ▼ to scroll through the parameter groups.
- Press ► button to open the submenu.
- Press ► button to view the parameters in the parameter group.
- Press ◀ button to return to the previous menu.
- To close the Programming Menu, press repeatedly ◀

Change parameter value:

Scroll to the corresponding parameter in the "Programming Menu" and press ► to enter edit mode.

- Use the ▲ and ▼ buttons to change parameter settings. Press the ▲ or ▼ button once to increase or decrease the parameter value by one unit. If the button is held down for more than five seconds, the parameter value will increase or decrease faster.
- To save the changes, press Menu. The settings on the display will be saved and the control panel will return to the parameter list.
- To cancel changes, press EXIT. The operator panel will ask if you want to confirm the cancellation, then return to the parameter table without saving the changes.

9.2 Parameter Write Protection

The programming menu can be locked to prevent users from modifying parameter settings. Can be write protected with parameter 15B switch parameter.

Lock programming menu:

1. Open the programming menu.
2. Open the extended menu.
3. Select 'Advanced'.
4. Enter the access password.
5. Select parameter 15B parameter write protection
6. Select and store 'Read Only'.

If the user attempts to change the parameter value after the parameter write protection is turned on, an error message is displayed:

Access Denied
Adjustment Lock

9.3 Access Password

Important parameters (parameter groups of 15 and above) are protected with four-digit secure access passwords to prevent unauthorized users from viewing or modifying parameter settings.

When the user attempts to enter the restricted parameter group, the operation panel prompts for a password. The programming session only requires the user to enter a-access password. Authorization-is valid until the user closes the menu.

To enter the access code, use ◀ and ▶ buttons to select a digit, and then use the ▲ and ▼ buttons to change the value. When all four digits are the same as the access code, press Menu (STORE)(storage). The operation panel will display a confirmation message before continuing.

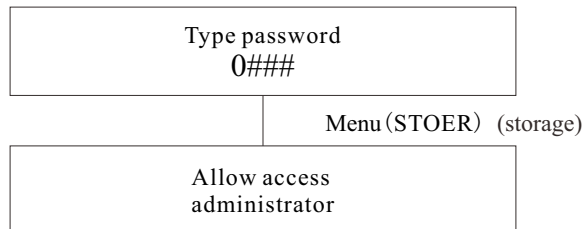

To change the access code, use parameter 15A.

Simulation tools and counter resets can also be protected with secure access codes.

The default access password is 0000.

9.4 Quick Setup

The Quick Setup menu allows you to quickly configure the soft starter for common applications. The soft starter selects the parameters related to the application and recommends typical settings. You can adjust each parameter according to your actual needs. Always set parameter 1A, the rated current of the motor to match the rated current indicated on the motor plate. The recommended value is the minimum rated current of the starter.

On the screen, the highlighted value is the recommended value, and the value marked with ▶ is the loaded value.

Application	Parameter	Suggested Value
Centrifugal pump	Motor rated current	Depending on model
	Starting method	Adaptive Control
	Adaptive starting curve	Early acceleration
	Start ramp time	10 seconds
	Stop mode	Adaptive Control
	Adaptive stop curve	Deceleration
	Stop time	15 seconds
Submersible pump	Motor rated current	Depending on the model.
	Starting method	Adaptive Control
	Adaptive starting curve	Speed up early.
	Start ramp time	5 seconds
	Stop mode	Adaptive Control
	Adaptive stop curve	After decelerating.
	Stop time	5 seconds
Damped fan	Motor rated current	Depending on model
	Starting method	Constant current
	Current limit	350%
Undamped fan	Motor rated current	Depending on model
	Starting method	Adaptive Control
	Adaptive starting curve	Constant acceleration
	Start ramp time	20 seconds
	Starting limit time	30 seconds
	Locked rotor time	20 seconds
	Screw compressor	Motor rated current
Starting method		Constant current
Start ramp time		5 seconds
Current limit		400%
Reciprocating compressor	Motor rated current	Depending on model
	Starting method	Constant current

Programming Menu

	Start ramp time Current limit	5 Second 450%
Conveyor belt	Motor rated current Starting method Start ramp time Current limit Stop mode Adaptive stop curve Stop time	Depending on model Constant current 5 seconds 400% Adaptive Control Constant deceleration. 10 seconds
Rotary crusher	Motor rated current Starting method Start ramp time Current limit Starting limit time Locked rotor time	Depending on model Constant current 10 seconds 400% 30 seconds 20 seconds
Jaw Crusher	Motor rated current Starting method Start ramp time Current limit Starting limit time Locked rotor time	Depending on model Constant current 10 seconds 450% 40 seconds 30 seconds

9.5 Standard Menu

The standard menu provides access to common parameters, and users can configure the soft starter according to their application needs. For detailed information on each parameter, see Parameter Descriptions on page 37.

		Parameter group	Default Setting
1		Motor data-1	
	1A	Motor rated current	Depending On Model
2		Start / Stop Mode-1	
	2A	Starting method	Constant Current
	2B	Start ramp time	10s
	2C	Initial current	350%
	2D	Current limit	350%
	2H	Stop mode	Taxi Stop
	2I	Stop time	0s
3		Automatic start / stop	
	3A	Automatic start mode	Turn Off
	3B	Auto start time	1m
	3C	Automatic stop mode	Turn Off
	3D	Auto stop time	1m
4		Protection settings	
	4A	Starting limit time	20s
	4C	Under current	20%
	4D	Undercurrent delay	5s
	4E	Instantaneous overcurrent	400%
	4F	Instantaneous overcurrent delay	0s
	4G	Phase sequence	Any Order
6		Enter	
	6A	Input A function	Motor Parameter Selection
	6B	Enter A name	Input Trip
	6C	Input A tripped	Always Open
	6D	Input A Trip Delay	0s
	6E	Input A initial delay	0s

Programming Menu

	6F	Input B function	Input trip (N / 0)
	6G	Enter B name	Input trip
	6H	Input B tripped	Always open
	6I	Input B trip delay	0s
	6J	Input B initial delay	0s
7		Output	
	7A	Relay a function	Main contactor
	7B	Relay a opening delay	0s
	7C	Relay a off delay	0s
	7D	Relay B function	Run
	7E	Relay B on delay	0s
	7F	Relay B off delay	0s
	7G	Relay C function	Tripping operation
	7H	Relay C on delay	0s
	7I	Relay C off delay	0s
	7M	Low current indication	50%
	7N	High current indication	100%
	7O	Motor temperature indication	80%
8		Monitor	
	8A	Language	English
	8B	F1 button function	Auto start / stop setting
	8C	F2 button function	Not set up
	8D	Display current or power	Electric current
	8E	Top left corner of screen	Starter status
	8F	Top right corner of screen	Blank
	8G	Bottom left corner of screen	Operating hours
	8H	Bottom right corner of screen	Analog input

9.6 Extended Menu

The extended menu provides access to all programmable parameters of the soft starter.

		Parameter group	Default setting
1		Motor Data-1	
	1A	Rated current of motor	Depending on Model
	1B	Locked to f time	0m: 10s
	1C	Locked rotor current	600%
	1D	Service factor of motor	105%
2		Start / stop MODE-1	
	2A	Starting mode	Constant current
	2B	Starting ramp time	10 s
	2C	Initial current	350%
	2D	Current limit	350%
	2E	Adaptive starting curve	Constant acceleration
	2F	Jump start time	0000ms
	2G	Jump start amplitude	500%
	2H	Stop mode	Taxi stop
	2I	Stopping time	0m:00s
	2J	Adaptive stop curve	Constant deceleration
	2K	Adaptive control gain	75%
	2L	Braking torque	20%
	2M	Braking time	0m:01s

Programming Menu

3		Auto start / stop	
	3A	Auto start mode	OFF
	3B	Auto start time	00h:01m
	3C	Automatic stop mode	OFF
	3D	Auto stop time	00h:01m
4		Protection settings	
	4A	Starting limit time	0m:20s
	4B	Starting limit Time-2	0m:20s
	4C	Under current	20%
	4D	Under current delay	0m:05s
	4E	Instantaneous overcurrent	400%
	4F	Instantaneous overcurrent delay	0m:00s
	4G	Phase sequence	Any order
	4H	Current imbalance	30%
	4I	Current unbalance delay	0m:03s
	4J	frequency measurement	Starting and running
	4K	Frequency change	± 5Hz
	4L	Frequency delay	0m:01s
	4M	Restart delay	10s
	4N	Motor temperature measurement	No measurement
	4O	Earth fault current	100 mA
	4P	Earth fault delay	0m:03s
	4Q	Undervoltage	100V
	4R	Undervoltage delay	5s
	4S	Overvoltage	800V
	4T	Overvoltage delay	5s
5		Automatic reset trip	
	5A	Automatic reset function,	Turn off automatic reset
	5B	Maximum reset times	1
	5C	A / b reset delay	00m:05s
	5D	C reset delay	05 m
6		input	
	6A	Input a function	Motor parameter selection
	6B	Enter a name	Input tripping
	6C	Input a trip	Always open
	6D	Input a trip delay	0m:00s
	6E	Input a initial delay	0m:00s
	6F	Input B function	Input trip (n / 0)
	6G	Enter B name	Input tripping
	6H	Input B trip	Always open
	6I	Input B trip delay	0m:00s
	6J	Input B initial delay	00m:00s
	6K	Input C function	shut
	6L	Input D function	shut
	6M	Remote reset logic	Normally closed (N/C)
	6N	Analog input trip	No tripping
	6O	Analog input range	2-10 V
	6P	Simulated trip point	50%
	6Q	Local) remote:	Always open
	6R	Telecontrol communication	Enable during remote control
7		output	
	7A	Relay a function	Main contactor

Programming Menu

	7B	Relay a opening delay	0m:00s
	7C	Relay a off delay	0m:00s
	7D	Relay B function	RUN
	7E	Relay B on delay	0m:00s
	7F	Relay B off delay	0m:00s
	7G	Relay C function	Tripping operation
	7H	Relay CF on delay	0m:00s
	7I	Relay C off delay	0m:00s
	7J	Relay D function	OFF
	7K	Relay e function	OFF
	7L	Relay F function	OFF
	7M	Low current indication	50%
	7N	High current indication	100%
	7O	Motor temperature indication	80%
	7P	Analog output a	Current (% rated current)
	7Q	Analog a range	4-20 mA
	7R	Analog a max	100%
	7S	Analog a min	000%
	7T	Analog output B	Current (% rated current)
	7U	Analog B range	4-20 mA
	7V	Analog B Max	100%
	7W	Analog B min	000%
8		Monitor	
	8A	language	English
	8B	F1 button function	Auto start / stop setting
	8C	F2 button function	Not set up
	8D	Display current or power	Electric current
	8E	Top left corner of screen	Starter status
	8F	Top right corner of screen	blank
	8G	Bottom left corner of screen	Operating hours
	8H	Bottom right corner of screen	Analog input
	8I	graphic data	Current (% rated current)
	8J	Graphic display period	10s
	8K	Graphic display maximum	400%
	8L	Graphic display minimum	000%
	8M	Current calibration	100%
	8N	Main supply voltage	400 V
	8O	Voltage calibration	100%
9		Motor data-2	
	9A	Double thermal protection model	Single model
	9B	Motor rated current - 2	Depending on Model
	9C	Lock to Time-2	0m:10s
	9D	Locked rotor current-2	600%
	9E	Motor Service factor-2	105%
1 0		Start / stop mode-2	
	10A	Starting mode-2	Constant current
	10B	Starting ramp-2	0m:10s
	10C	Initial current - 2	350%
	10D	Current LIMIT-2	350%
	10E	Adaptive starting curve-2	Constant acceleration
	10F	Jump start Time-2	0000 ms
	10G	Jump start amplitude-2	500%

Programming Menu

	10H	Stop mode-2	Taxi stop
	10I	Stop Time-2	0m:00s
	10J	Adaptive stop curve-2	Constant deceleration
	10K	Adaptive control gain-2	75%
	10L	Brake torque-2	20%
	10M	Braking Time-2	0m:01s
11		RTD temperature	
	11A	<i>RTD/PT100 A °C</i>	50 °C (122 °F)
	11B	<i>RTD/PT100 B °C</i>	50 °C (122 °F)
	11C	<i>RTD/PT100 C °C</i>	50 °C (122 °F)
	11D	<i>RTD/PT100 D °C</i>	50 °C (122 °F)
	11E	<i>RTD/PT100 E °C</i>	50 °C (122 °F)
	11F	<i>RTD/PT100 F °C</i>	50 °C (122 °F)
	11G	<i>RTD/PT100 G °C</i>	50 °C (122 °F)
12		Slip ring motor	
	12A	Motor data 1 ramp	Single slope
	12B	Motor data 2 ramp	Single slope
	12C	Conversion time	150 ms
	12D	Slip ring deceleration	50%
15		Advanced requires an access password. Default value: 000	
	15A	Access password	0000
	15B	Parameter write protection	Read and write
	15C	Emergency operation	Prohibit
	15D	Short circuit thyristor action	Three phase control only
	15E	Point torque	50%
16		protective measures	
	16A	motor overload	Starter trip
	16B	Starting limit time	Starter trip
	16C	Under current	Starter trip
	16D	Instantaneous overcurrent	Starter trip
	16E	Current imbalance	Starter trip
	16F	frequency	Starter trip
	16G	Input a trip	Starter trip
	16H	Input B trip	Starter trip
	16I	Motor thermistor	Starter trip
	16J	Starter communication	Starter trip
	16K	Network communication failure	Starter trip
	16L	heatsink OT	Starter trip
	16M	Battery clock failure	Starter trip
	16N	Grounding fault	Starter trip
	16O	<i>RTD/PT100 A</i>	Starter trip
	16P	<i>RTD/PT100 B</i>	Starter trip
	16Q	<i>RTD/PT100 C</i>	Starter trip
	16R	<i>RTD/PT100 D</i>	Starter trip
	16S	<i>RTD/PT100 E</i>	Starter trip
	16T	<i>RTD/PT100 F</i>	Starter trip
	16U	<i>RTD/PT100 G</i>	Starter trip
	16V	Retain	-
	16W	Retain	-
	16X	Low control voltage	Starter trip
20		limit	
		Factory use only	

9.7 Load / Save Settings

You must enter the access password to access the load / save settings menu, where you can:

- default value of Loading Soft Starter parameters
- reload the parameter settings previously saved in the internal file
- save the current parameter settings in the internal file

In addition to the factory default file, the soft starter can store two custom parameter files. Before you save user files, they contain default values.

Load or save parameter settings:

1. Open the programming menu.
2. Flip to load / save settings and press ► button.
3. Turn to the required function and press ► button.
4. When prompted for confirmation, select Yes to confirm or no to cancel. Then press the menu (store) button to load / save the selection.

Parameter settings upload / backup
 Load defaults
 Load spare
 Load user settings 1

Load defaults
 No
 Yes

After completing this operation, the screen displays a short confirmation message and then returns to the status screen.



Be careful

The saved file and the current working settings are stored in both the operation panel and the soft starter. Whenever you insert the dashboard into a new soft starter, the dashboard prompts you to synchronize the settings.

9.8 parameter description

1 motor data 1

The parameters in motor data 1 are used to configure the soft starter to match the connected motor. These parameters describe the operation characteristics of the motor, so that the soft starter can establish the temperature model of the motor.



Be careful

If delta connection method is adopted, input the rated current of motor with parameter 1a. The soft starter automatically detects whether the motor is connected by the star connection method or the triangle connection method, and calculates the correct current of the triangle connection.

1A - rated current of motor

Range: Depending on Model

Explain: Match the starter to the rated current of the connected motor. Set the rated current indicated on the motor label.

1B — locked rotor time

Range: 0:01-2:00(minutes: seconds) Default: 10 seconds

Explain: Sets the maximum time required for the motor to move from cold to maximum temperature with locked rotor current. Set according to motor data sheet.

1C — Locked rotor current

Range: 400%-1200% Rated current Default value: 600%

Explain: Set the locked rotor current of the connected motor as a percentage of the rated current. Set according to motor data sheet.

1D — Starting mode motor service factor

Range: 100%-130% Default value: 105%

Explain: Set the service factor of the motor used in the thermal protection model. If the motor operates at rated current, the service factor of the motor is 100%. Set according to motor data sheet.



Be careful

Parameters 1b, 1c and 1D determine the trip current of the motor overload protection. The default settings for parameters 1b, 1c and 1D provide motor overload protection: class 10, trip current, 105% of FLA (rated current) or equivalent.

2 start / stop mode 1

2A - starting mode

Options: Constant current (default)
adaptive control
Explain: Select soft start mode.

2B — Starting ramp time

Options: 1 - 180 (seconds) Default value: 10 seconds
Explain: Set the total start time of adaptive control starting or the ramp time of current ramp starting (from initial current to current limit).

2C — Initial current

Options: 100% - 600% rated current Default: 350%
Explain: Set the initial starting current for current ramp starting as a percentage of the rated current of the motor. Set the initial current so that the motor starts to accelerate immediately after starting. If current ramp starting is not required, set the initial current to the same value as the current limit.

2D — Current limit

Options: 100% - 600% rated current Default: 350%
Explain: Set the current limit of constant current soft start and current ramp soft start as the percentage of rated motor current.

2E — Adaptive starting curve

Options: Early acceleration
Constant acceleration (default)
Explain: Post acceleration
Select which curve the soft starter uses for adaptive control soft start.

2F — Jump start time

Options: 0-2000 ms Default: 0000 MS
Explain: Set the jump start duration. A setting of 0 disables jump start.

2G — Jump start amplitude

Options: 100% - 700% rated current Default: 500%
Explain:



Look out
Sudden start-up increases the torque of mechanical equipment. Before using this function, make sure that the motor, load and coupling can withstand additional torque.

2H — Stopping mode

Options: Taxi stop (default)
Explain: TVR soft stop
adaptive control
braking
Select the stop mode.

2I — Stopping time

Options: 0:00-4:00(Minute:seconds) Default: 0 (seconds)
Explain: Set the time required to soft stop the motor using a timed voltage ramp or adaptive control. At the same time, set the total stop time when the braking mode is adopted. If a main contactor is installed, it must remain closed until the end of the stop time. Use one of the programmable relays to control the main contactor.

2J—Adaptive stop curve

Options:	Early deceleration Constant deceleration (default) After deceleration
Explain:	Select which curve the soft starter uses for soft stop adaptive control.

2K — Adaptive control gain

Range:	1% - 200%	Default: 75%
Explain:	Adjust the performance of the adaptive control. This setting affects both the start control and the stop control.	



Be careful
We recommend that you leave the gain setting at the default value, unless the performance does not meet the requirements.
If the motor accelerates rapidly at the end of starting or decelerates rapidly at the end of stopping, increase the gain setting by 5% ^ 10%. If the motor speed fluctuates during start or stop, slightly decrease - a little gain setting.

2L — Braking torque

Options:	20%-100%	Default: 20%
Explain:	Set the brake torque used by soft starter to slow down the motor.	

2M — Braking time



Range:	1-30 (seconds)	Default: 1 second
Note:	set the duration of DC power supply during braking stop.	
Be careful	Parameter 2M and parameter 2I are used. See braking for details.	

3 Auto start / stop

The soft starter can be programmed to start and stop automatically after a specified delay or at a specified time of day. Automatic start and automatic stop can be set separately.

The auto start / auto stop operation can only be used in remote mode. In local mode, the starter will ignore all auto start / auto stop settings.



Look out.
The auto start timer covers all other controls. The motor may start without warning.



warning
This function should not be used with a two wire remote control.
The soft starter still receives start and stop commands from the remote input or serial communication network. To disable local control or remote control, use parameter 6q.
If auto start is enabled, but the user is still in the menu system, activate auto start after menu timeout (no operation board activity is detected within 5 minutes).

3A — Auto start mode

Option:	off (default) soft starter will not start automatically. After the timer stops next time, the soft starter will start automatically after the delay specified in parameter 3B.
Note:	the clock soft starter will start automatically at the time set in parameter 3B. Select whether the soft starter will start automatically after the specified delay or at the specified time of one day.

3B — Auto start time

Options:	00:01 - 24:00 (hour: minute)	Default: 1 minute
Explain:	Set the soft starter auto start time in 24-hour clock format.	

3C — Automatic stop mode

Option: off (default) soft starter will not start automatically.

After the timer stops next time, the soft starter will stop automatically after the delay specified in parameter 3D.

Explain: The clock soft starter will stop automatically at the time set in parameter 3D.

Select whether the soft starter will automatically stop after the specified delay or at the specified time of the day.

3D — Auto stop time

Range: 00:01 - 24:00 (hour: minute)

Default: 1 minute

Note: set the automatic stop time of soft starter according to the 24-hour clock format.

4 Protection settings

These parameters determine when to activate the protection mechanism of the soft starter. The activation point of each protection mechanism can be set according to the needs of the device.

The soft starter responds to the protection event by tripping, warning or writing the event to the event log.

The setting of protection measures (parameter setting 16 protection measures) determines the response.

The default response is trip. .



Look out

The protection setting is very important for the safety of soft starter and motor.

The cancellation of the protection mechanism may endanger the safety of the equipment and should only be used in case of emergency.

4A 4B—Starting limit time

The starting limit time is the maximum time required for the soft starter to try to start the motor. If the motor does not transition to operating mode within the programmed limits, the starter trips. Set a time that is slightly longer than the normal start-up time. A setting of 0 disables the start limit time protection.

Range: 0:00 - 4:00 (minutes: seconds)

Default: 20 seconds

Note: parameter 4A sets the main motor time, parameter 4B (start limit Time-2) sets the second group of motor time.

4C — Under current

Options: 0%-100%

Explain: Set the under current protection trip point according to the motor rated current percentage.

Set to a value between the normal operating current range of the motor and the magnetizing (no-load) current of the motor (usually 25% to 35% of the rated current). Setting 0% disables the under current protection.

4D — Under current delay

Options: 0:00-4:00 (minutes: seconds)

Default: 5 seconds

Explain: Reduce the response speed of soft starter to under current, and avoid tripping due to instantaneous fluctuation.

4E — Instantaneous overcurrent

Options: 80% - 600% rated current

Default: 400%

Explain: Set the instantaneous overcurrent protection trip point according to the motor rated current percentage.

4F — Instantaneous overcurrent delay

Options: 0:00-1:00 (minutes: seconds)

Default: 0 seconds

Explain: Reduce the response speed of the soft starter to the instantaneous overcurrent and avoid tripping due to the instantaneous fluctuation.

4G — Phase sequence

Options: Any order (default)
Forward
reverse

Explain: Select which phase sequence the soft starter will allow when starting. During the pre start check, the starter checks the phase sequence of its input terminals and trips if the actual phase sequence does not match the selected option.

4H — Current imbalance

Options: 10%-50%

Default: 30%

Explain: Set the current unbalance protection trip point.

4I — Current unbalance delay

Range: 0:00 - 4:00 (minutes: seconds) Default: 3 seconds
 Note: reduce the response speed of the soft starter to the current imbalance and avoid tripping due to instantaneous fluctuation.

4J — frequency measurement

Options: No measurement
 Start time only
 Start and run (default)
 Runtime only
 Explain: Determine when and if the starter will monitor the frequency trip.

4K — Frequency change

Options: ± 2 Hz
 ± 5 Hz (default)
 ± 10 Hz
 ± 15 Hz
 Explain: Select the allowable frequency variation of soft starter.

4L — Frequency delay

Options: 0:01 - 4:00 (minutes: seconds) Default: 1 seconds
 Explain: Reduce the response speed of soft starter to frequency fluctuation, and avoid tripping due to instantaneous fluctuation.



Be careful
 If the power frequency is lower than 35 Hz or higher than 75 Hz, the starter trips immediately.



Look out
 If the motor operates outside the specified frequency range for a long time, it may cause motor damage and permanent failure.

4M — Restart delay

Options: 00:01-60:00 (minute: Second) Default: 10 seconds
 Explain: A soft starter can be configured to force a delay from the end of the stop to the start of the next start. During the restart delay, the display shows the time remaining before another start can be attempted.



Be careful
 The restart delay starts at the end of each stop. Any changes to the restart delay setting will take effect after the next stop.

4N — Motor temperature measurement

Options: Do not measure (default)
 Measure
 Explain: Select whether the soft start verifies that the motor has sufficient thermal capacity to ensure successful start. The soft starter compares the calculated temperature of the motor with the temperature rise of the last motor start, and starts only when the motor is cooled enough to start successfully.

4O — Earth fault current

Options: 20mA - 50A (grade 21) Default: 100mA
 Explain: Set the ground fault protection trip point.

4P — Earth fault delay

Options: 00:01-4:00 (minute: Second) Default: 3 seconds
 Explain: Reduce the response speed of soft start to ground fault fluctuation and avoid tripping due to instantaneous fluctuation.



Be careful
 The earth fault protection can only be used when the RTD / PT100 and the earth fault protection card are installed.

4Q — Retain

This parameter is reserved for internal use.

6 input

Soft start has two programmable inputs, which can control the soft start remotely. If necessary, you can use the I / O expansion card to add two inputs.

6A — Input a function

Options: Motor parameter selection (default) can configure two sets of independent motor data for the soft starter.

To use the auxiliary motor data, parameter 6A must be set to 'motor parameter selection'. When a start command is issued, C53 and C54 must be closed.

The soft starter checks which motor data to use at startup and uses this motor data throughout the start / stop process.

Input trip (N / O)

The soft starter can be tripped with input A. When parameter 6A is set to input trip (N / O), C53 and C54 close the circuit and trip the soft starter.

Input trip (N / C)

When parameter 6A is set to input trip (N / C), C53 and C54 are open to trip the soft starter.

Local / remote selection

You can use input A to select local control or remote control without using the L / R (local / remote) button on the operation panel. When this input is off, the starter is in local control mode and can be started via the operation panel. When this input is closed, the starter control is

Remote control mode. With the START and L / R (local / remote) buttons disabled, the soft starter ignores any local / remote selection commands from the serial communication network.

Emergency operation

To use input A to select local or remote control, parameter 6Q must be set to "Always on" or "On when the motor is stopped".

In the emergency running mode, the soft starter continues to run to stop, ignoring all trips and warnings (See parameter 15C for details).

Disable starter

When C53 and C54 are closed, emergency operation is activated. When the circuit is open, the emergency operation ends and the soft starter stops the motor.

The soft starter can be disabled via the control input. Opening C53, C54 disables the starter. The soft starter does not respond to the start command. If the soft starter is running, it will allow the motor to coast to stop and ignore the soft stop mode set in parameter 2H.

Jog forward

Jog reverse

Activate jog forward operation (only available in remote control mode).

Activates jog reverse operation (only available in remote control mode).

Explain:

Select the input A function.

6B — Enter a name

Options: Input trip (default) no flow

Low pressure

high pressure

Pump failure

Low level

High level

Disable starter

Controller

PLC

Vibration alarm

Explain: Select the message to be displayed on the operation panel when input A is activated.

6C — Input A tripped

Options: Always on (default) It may trip at any time after the soft starter is powered up.

During operation only, the soft starter may trip when it is running, stopped or started.

Trip only Only trips when the soft starter is running.

Explain: Select when an input trip occurs.

6D — Input A Trip Delay

Range: 0:00-4:00 (minutes: seconds)

Default: 0 seconds

Explain: Set the delay from input activation until the soft starter trips.

6E — Input A initial delay

Range:	0:00-30:00 (minutes: seconds)	Default: 0 seconds
Explain:	Set the delay before the input trip occurs. The initial delay is calculated from the start signal received. The input state is ignored until the initial delay has elapsed.	

6F 6G 6H 6I 6J — Input B tripped

Parameters 6F ~ 6J configure input B in the same way as parameters 6A ~ 6E configure input A. See Input A for details.

6F	Input B function (default: input trip (N / 0))
6G	input B name (default: input trip)
6H	Input B trip (default: always on)
6I	Input B trip delay (default: 0:00)
6J	Input B initial delay (default: 0:00)

6K、6L — Input C and input D

Parameters 6A and 6K select the function of input C and input D. See parameter 6A for details. Input C and Input D are only available if an input / output expansion card is installed.

Options:	Motor parameter selection Local / remote selection. Emergency operation Disable starter (normally closed) Off (default)
----------	---

6M — Remote reset logic

Options:	Normally closed (N / C) (default) Normally open (N / 0)
Explain:	Select whether the soft starter remote reset input (terminals C41, C42) is normally open or normally closed.

6N — Analog input trip

If necessary, connect the analog input to the soft starter. External devices can activate the analog input to trip the soft starter in response to external conditions.

Options:	Not tripped (default) Over trip Too low trip
Explain:	Select the response of the soft starter to the analog input signal.

6O — Analog input range

Options:	0-10V (default) 2-10V
Explain:	Select the analog output range.

6P — Analog trip point

Options:	0% - 100%	Default: 50%
Explain:	Set the signal level when an analog input trip occurs as a percentage of the maximum input signal.	

6Q — Local / remote

Options:	Always on Always enabled Open when motor is stopped Enable when starter is off Local control only Remote control only	L / R (local / remote) button. L / R (local / remote) button. Disable all remote inputs. Disable local control buttons (START, RESET and L / R (local / remote))
Explain:	Select when to use the L / R (local / remote) button to switch between local and remote control, enable or disable the local control button and remote control input. The STOP button on the operator panel is always enabled.	



Be careful
The STOP button on the operator panel is always enabled. When using two-wire remote control, if the remote start / stop input and remote reset input are still active, the soft starter will restart.

6R — Remote communication

- Options:** Disabled during remote control
Enabled during remote control (default)
- Explain:** Select whether the starter receives start and stop commands from the serial communication network in remote control mode.
Reset commands, forced communication trip commands, and local / remote commands are always enabled.

7 Output

Soft start has three programmable outputs that can be used to signal different operating conditions to related equipment. Three additional outputs on the input / output expansion card can be used.

7A — Relay A function

Options: Turn Off	Relay A is not used.
Main Contactor (default)	When the soft starter receives the start command, the relay closes. Keep it closed during the power.
Run	When the starter switches to the running state, the relay closes.
Trip	When the starter trips, the relay closes (see parameter 16A~16X).
Caveat	When the starter issues a warning, the relay is closed (see parameters 16A ~ 16X).
Low Current Indication	When the low current indication is activated (see parameter 7M Low current indication, when the motor is running), the relay is closed.
High Current Indication	When the high current indication is activated (see parameter 7N High current indication, when the motor is running), the relay is closed.
Motor Temperature Indication	When the motor temperature indication is activated (see parameter 7O Motor temperature indication), the relay is closed.
Input A Tripped	When input A activates the soft starter, the relay closes.
Input B Tripped	When input B activates the soft starter to trip, the relay closes.
Motor Overload (thermal Model)	When the starter trips due to motor overload, the relay closes.
Current Imbalance	When the starter trips due to current imbalance, the relay closes.
Under Current	When the starter trips due to undercurrent, the relay closes.
Instantaneous Overcurrent	When the starter trips due to transient overcurrent, the relay closes.
Frequency	When the starter trips due to frequency, the relay closes.
Ground Fault	When the starter trips due to a ground fault, the relay closes.
Radiator Overheating	When the starter trips due to overheating of the radiator, the relay closes.
Missing Phase	When the starter trips due to a phase loss, the relay closes.
Motor Thermistor	When the starter trips due to the motor thermistor, the relay closes.
Changeover Contactor	When the high rotor resistance current ramp reaches full voltage, the relay closes and can be used with slip ring motors.
Undervoltage	Not suitable for soft starters.
Ready	When the starter is in the ready state, the relay is closed.

7B — Relay A On Delay

Note: Select relay A function (normally open)

Range: 0:00-5:00 (minutes: seconds)	Default: 0 seconds
Explain: Set relay A closing delay.	

7C — Relay A power-off delay

Range: 0:00-5:00 (minutes: seconds)	Default: 0 seconds
Explain: Set relay A reopen delay.	

7R — Analog A maximum

Range:	0% - 600%	Default: 100%
Explain:	Calibrate the upper limit of the analog output to match the signal measured on an external current measurement device.	

7S — Analog A minimum

Range:	0% - 600%	Default: 0%
Explain:	Calibrate the lower limit of the analog output to match the signal measured on an external current measurement device.	

7T、7U、7V、7W—Analog output B

Parameter 7T~7W configures the operation of analog output B in the same way as parameter 7P~7S configures analog output A. See Analog Output A for details.
Analog output B is only available if an input / output expansion card is installed.

8 Monitor

You can use these parameters to customize the controller for individual user needs.

8A-Language

Options:	English (default) Chinese Español Deutsch Português Français Italiano Russian
Explain:	Select the language in which messages and feedback are displayed on the dashboard.

8B and 8C—F 1 and F 2 button functions

Options:	Not set Automatic start / stop setting Jog forward Jog reverse
Explain:	Select the function of the F1 and F2 buttons on the operation panel.



Note
No access password is required to use the F1 and F2 buttons. Regardless of the setting of parameter 15B, users can use these functions.
Parameter write protection.

8D—Display current or power

Options:	Current (default) Motor Power
Explain:	Select whether the soft starter displays current (Amps) or motor power on the main monitoring screen.

8E、8F、8G、8H—User programmable screen

Option: Blank selected area does not display data, but displays long messages to avoid overlap.
Starter status Starter working status (starting, running, stopping or tripping).
Can only be displayed in the upper left (default) and lower left corners of the screen.
Motor current Three-phase average current.
Motor power factor Motor power factor as measured by the soft starter.
Power frequency The average frequency measured in three phases.
Motor power Motor operating power kW.
Motor horsepower Motor operating power HP.
Motor temperature The motor temperature calculated using the thermal protection model.
Kilowatt hours The number of kilowatt hours consumed by the motor through the soft starter.
Running hours The number of hours the motor has been running through the soft starter.
Analog input Analog input A level (see parameters 6N ~ 6P).
This setting is only available if an input / output expansion card is installed.

Description: Select what information the programmable monitor screen displays.

- 8E Upper left corner of the screen Default value: Starter status
- 8F Upper right corner of the screen Default value: blank
- 8G Screen bottom left corner Default value: running hours
- 8H Lower right corner of the screen Default value: analog input

8I — Graphic data

The soft starter uses real-time performance charts to report characteristics of important operating parameters.

Option: Current (% rated current) (default) Current expressed as a percentage of the motor's rated current.

Motor temperature (%) Motor temperature expressed as a percentage of motor thermal capacity.

Motor power (%) Measured motor kilowatt power, expressed as a percentage of maximum power.

The motor apparent power measured by motor capacity (%) is expressed as a percentage of the maximum apparent power.

Motor power factor Motor power factor as measured by the soft starter.

Measurement: Measured motor power: $\sqrt{3} \times \text{average current} \times \text{power reference voltage} \times \text{measured power factor}$

Maximum motor power: $\sqrt{3} \times \text{rated motor current} \times \text{power reference voltage}$. Assume power factor of 1

Measured motor apparent power: $\sqrt{3} \times \text{average current} \times \text{power supply reference voltage}$.

Maximum motor apparent power: $\sqrt{3} \times \text{rated motor current} \times \text{power reference voltage}$

Description: Select what information the performance graph displays.

8J — Graphic display period

- Options: 10 seconds (default)
 30 seconds
 1 minute
 5 points
 10 points
 30 points
 1 hour

Explain: Set the graphic time scale. Graphics replace old data with new data.

8K — Graphic maximum

Range: 0% – 600% Default: 400%

Explain: Adjust the upper limit of the performance graph.

8L — Graphic minimum

0% – 600% Default: 0%

Adjust the lower limit of the performance graph.

8M — Current calibration

Range: 85% - 115% Default: 100%

Explain: Calibrate the soft starter's current monitoring circuit to match the external current measurement equipment.

Use the following formula to determine the necessary adjustment:

$$\text{calibration (\%)} = \frac{\text{Current shown on soft starter display}}{\text{Current measured by external device}}$$

$$\text{such as } 102\% = \frac{66\text{A}}{65\text{A}}$$



Attention

This adjustment affects all current-based functions and protections.

8N — Power reference voltage

	Range:	100–690 V	Default: 400V
	Explain:	Set the power frequency voltage of the operation panel monitoring function. Use this setting to calculate motor power and apparent power (kVA), but it will not affect the control or protection of the motor.	
80	Keep		
	Explain:	This parameter is reserved for future use.	

9 Motor data-2

The soft starter can support two different sets of motor start and stop data.

- If you want to use the soft starter with two different motors (such as working / standby configuration), use parameter 9A to select the dual thermal protection model and configure parameters 9B ~ 9E according to the second motor.
- To use a soft starter with two sets of different motor data for the same motor (two-speed motors or applications with varying starting conditions), use parameter 9A to select the single thermal protection model, and use parameters 10A to 10G to configure the start and stop curves as required. The soft starter will ignore parameters 9B ~ 9E and will use the settings of the main motor.

To select the second set of motor data, a programmable input must be configured as a parameter setting selection (parameters 6A and 6F). This input must be activated when the soft starter receives a start signal.



Attention

Only when the soft starter is stopped, which set of motor data can be selected.

9A — Double thermal protection model

Options: Single model (default)
Dual model

Explain: Activate the dual thermal protection model. The dual thermal protection model is required only when the soft starter controls two different motors.

9B — Motor rated current 2

Range: Depending on model
Explain: Set the auxiliary motor rated current.

9C — Locked rotor time -2

Range: 0: 01-2: 00 (minutes: seconds) Default: 10s
Explain: Set the maximum time required for the motor to reach the maximum temperature from the cold state with locked rotor current. Set according to the motor data sheet.

9D — Stall current 2

Range: 400% - 1200% Rated current Default: 600%
Explain: Set the locked rotor current of the connected motor as a percentage of the rated current. Set according to the motor data sheet.

9E — Motor service factor 2

Range: 100% - 130% Rated current Default: 105%
Explain: Set the service factor for the second group of motors.

10 Start / stop method 2

10A — Starting method 2

Options: Constant current (default)
Adaptive Control
Select the soft start method.

10B — Starting ramp-2

Range: 1 - 180 (s) Default: 10s
Explain: Set the total start time of the adaptive control start or the ramp time of the current ramp start (from the initial current to the current limit).

10C — Initial current 2

Range:	100% - 600%	Default: 350%
Options:	Set the initial starting current of the current ramp start as a percentage of the rated motor current. Set the initial current so that the motor starts to accelerate immediately after starting to start. If a current ramp start is not required, set the initial current to the same value as the current limit.	

10D — Current limit 2

Range:	100%-600% Rated current	Default: 350%
Options:	Set the current limit for constant current soft start and current ramp soft start as a percentage of the motor's rated current.	

10E — Adaptive starting curve 2

Option:	Early acceleration Constant acceleration (default) Post-acceleration	
Explain:	Select which curve the soft starter uses for adaptive control soft start.	

10F — Jump start time -2

Range:	0-2000 (ms)	Default: 0000ms
Explain:	Set the kick start duration. Setting 0 disables kick start.	

10G — Recoil start amplitude 2

Range:	100% — 700% Rated current	Default: 500%
Explain:	Set the kick start current amplitude.	

10H — Stop mode 2

Options:	Taxi stop (default) TVR soft stop Adaptive Control Brake	
Explain:	Select the stop method.	

10I — Stop time 2

Range:	0:00 - 4:00 (Minutes: seconds)	Default: 0s
Explain:	Set the stop time.	

10J — Adaptive stop curve 2

Options:	Early deceleration Constant deceleration (default) Deceleration	
Explain:	Select which curve the soft starter uses for adaptive control soft stop.	

10K — Adaptive control gain 2

Range:	1% - 200%	Default: 75%
Explain:	Tuning the performance of adaptive control. This setting affects both start control and stop control.	

10L — Brake torque 2

Range:	20%-100%	Default: 20%
Explain:	Set the amount of braking torque used by the soft starter to slow down the motor.	

10M — Braking Time-2

Range:	1-30 (s)	Default: 1s
Explain:	Set the duration of DC power supply during braking stop.	

11 RTD Temperature

The soft starter has one RTD / PT100 input, which can be installed with six other PT100 inputs through this RTD / PT100 and ground fault protection card.

When the temperature exceeds a specified point, these inputs trip the soft starter. You can set a different trip temperature for each input.

Only after installing the RTD / PT100 and ground fault protection card, can you use the PT100 to input B ~ G.

Range: 0-250°C Default: 50°C

Explain: Set the RTD / PT100 input trip point.

- 11A RTD A Trip temperature
- 11B RTD B Trip temperature
- 11C RTD C Trip temperature
- 11D RTD D Trip temperature
- 11E RTD E Trip temperature
- 11F RTD F Trip temperature
- 11G RTD G Trip temperature

12 Slip Ring Motor

You can use these parameters to configure the soft starter for use with slip ring motors.

12A 12B—Motor data 1 ramp and motor data 2 ramp

Options: Single slope (default)
Shuangpo

Explain: Select whether to use single current ramp or dual current ramp for soft start. Set a single slope for the non-slip ring induction motor and a double slope for the slip ring induction motor.

Parameter 12A selects the main motor ramp configuration, and parameter 12B selects the auxiliary motor ramp configuration.

12C—Conversion time

Options: 100-500 (ms) Default: 150 ms

Explain: Set the delay from the closing of the rotor resistance relay to the start of the low resistance current ramp. Set the switching time so that the contactor has enough time to close, but the motor does not decelerate.

Parameter 12C only applies if parameter 12A or 12B is set to "Double Ramp" and an output relay is set to changeover contactor.

12D—Slip ring deceleration

Options: 10%-90% Default: 50%

Explain: Set the conduction level when the rotor resistor is closed, as a percentage of full conduction.

Setting slip ring deceleration can avoid current pulse, but the motor has sufficient speed to start normally.

15 Advanced

15A—Access password

Options: 0000 - 9999 Default: 0000

Explain: Set an access password to control access to restricted sections of the menu.



Use ◀ and ▶ buttons to select the digit to be changed, and use the ▲ and ▼ buttons to change the value.

Note

If you forget the access password, please contact your local supplier to obtain the master access password. You can use this to reset the new access password.

15B—Parameter write protection

Options: Read and write (default) allows the user to modify parameter values on the programming menu.

Read Only Does not allow the user to modify parameter values on the programming menu.

You can still view the parameter values.



Explain: Select whether the operator panel allows parameters to be changed via the programming menu.

Note

Any changes to the parameter write protection settings will take effect after the programming menu is closed.

15C—Emergency operation

Options: Disabled (default)
Enable

Explain: Select whether the soft starter allows emergency operation. In emergency running mode, the soft starter starts (if not already running) and continues to work until the end of emergency running, ignoring stop commands and trips. Emergency operation is controlled by programmable parameters.



Attention

It is not recommended to use emergency operation continuously. Emergency operation may damage the life of the starter because all protections and trips are disabled. Using the starter in emergency operation mode will void the product warranty.

15D—Short-circuit thyristor action

Options: Three-phase control only (default)
Two-phase control

Explain: Select whether the soft starter allows two-phase control. For critical applications, if one phase of the soft starter is damaged, the soft starter is allowed to use two-phase control to control the motor. Two-phase control can only be used after the soft starter has tripped and reset due to "Lx-Tx short circuit".



Attention

Two-phase control can adopt two-phase soft-start technology, so special care must be taken when determining the specifications of the circuit breaker and protection. Contact your local supplier for assistance.



Attention

Only motors connected by star connection support two-phase control. If the soft starter is connected using a delta connection method, two-phase control does not work.

The next time the control power is applied, the starter will trip due to an Lx-Tx short circuit. If the control power is turned on again between two starts, the two-phase control does not work.

15E—Jogging torque

The soft starter can be jogged at low speed, which is convenient for precise adjustment of the belt position and flywheel position. Both jog forward and jog reverse.

Range: 20%-100%

Default: 50%

Explain: Set the jog operation current limit.

16 Protective measures

These parameters define how the soft starter responds to different protection events. The soft starter can trip, issue a warning or ignore different protection events as needed.

Writes all protection events to the event log. The default action for all protections is to trip the soft starter.

16N ground fault protection and 16P ~ 16U RTD / PT100 protection can only be used after installing the RTD / PT100 and ground fault protection card.



Attention

The removal of the protection mechanism may endanger the safety of the starter and the motor and should only be used in an emergency.

16A~16X — Protective measures

Options: Starter trip (default)
Alarm and record
Record only

Explain: Select the response of the soft starter to each protection.

- 16A Motor overload
- 16B Starting limit time
- 16C Under current
- 16D Instantaneous overcurrent
- 16E Current imbalance
- 16F Frequency
- 16G Input a tripped
- 16H Input b tripped
- 16I Motor thermistor
- 16J Starter communication
- 16K network communication failure
- 16L radiator overheating
- 16M battery / clock failure
- 16N ground fault
- 16O ~ 16U RTD A ~ G overheating
- 16V reserved
- 16W reserved
- 16X low control voltage

Chapter 10 Application Examples

The following series of application notes can help you understand the advanced installation and configuration of soft starters under specific performance requirements. Application notes explain various application conditions, including brake operation, jog operation, pumping options, and advanced protection options.

10.1 Installation With Main Contactor

The soft starter is installed together with the main contactor (AC3 class). The control voltage must be input at the input of the contactor.

The main contactor is controlled by the soft contactor main contactor output. This output is assigned to output relay A (terminals 13, 14) by default.

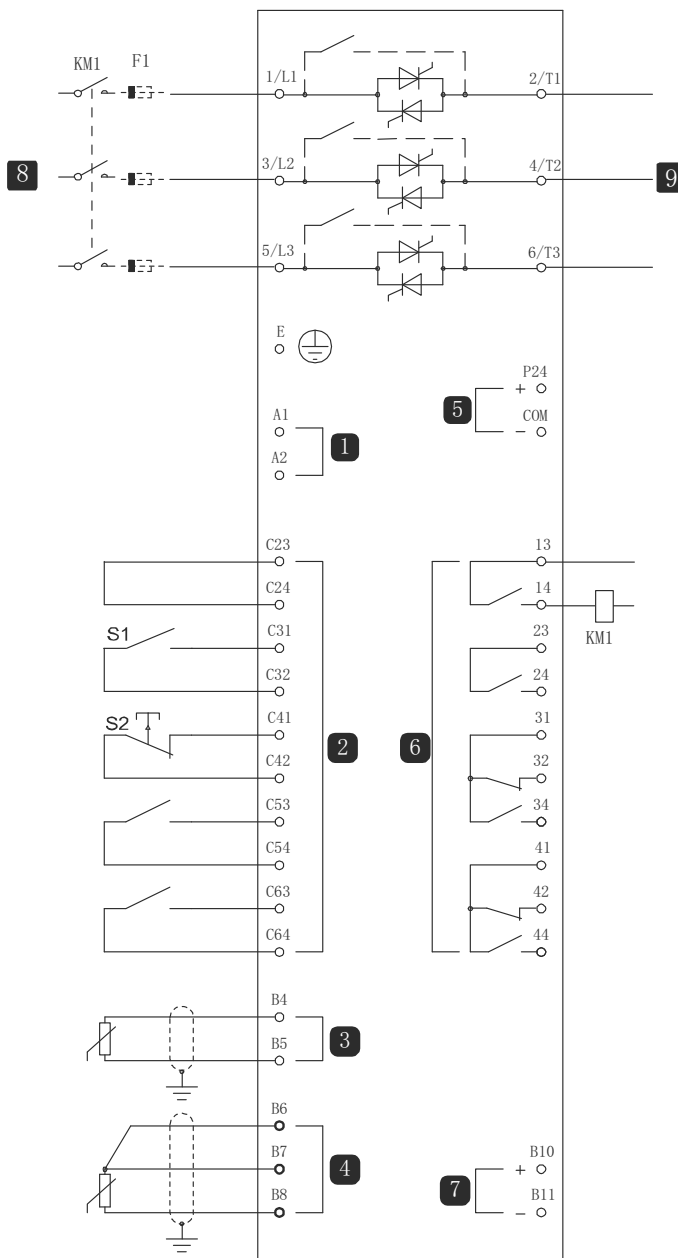

1	Control voltage (depending on model)
2	Remote control input
3	Motor thermistor input
4	RTD / PT100 input
5	24VDC output
6	Relay output
7	Analog output
8	Three-phase power
9	Motor terminal
KM1	Main contactor
F1	Semiconductor fuse (optional)
S1	Start / stop contact
S2	Reset contact
13, 14	Relay output A
23, 24	Run relay output
31, 32, 34	Relay output B
41, 42, 44	Relay output C

Parameter settings:

- parameter 7A relay A function

Select 'Main Contactor'-Assign relay output A as the main contactor function (default setting).

10.2 Installation With External Bypass Contactor

The soft starter is installed together with an external bypass contactor (AC1 class). The bypass contactor is controlled by the soft starter's running output (terminals 23, 24).

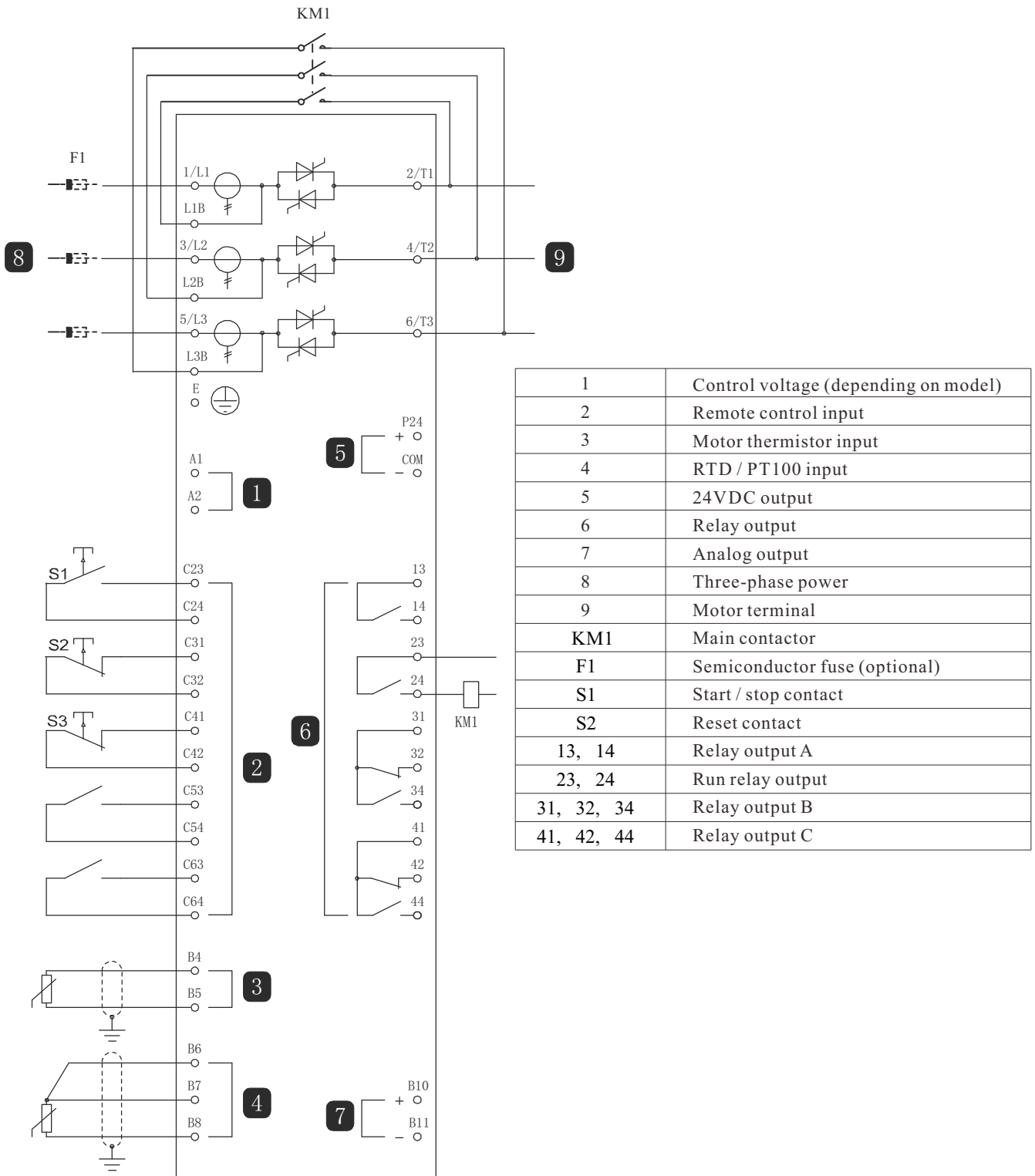

Parameter settings:

- No special settings are required.

10.3 Emergency Operation

During normal operation, the soft starter is controlled by two-wire remote control signals (terminals C31, C32).

Emergency operation is controlled by a two-wire circuit connected to input A (terminals C53, C54). When input A is closed, the soft starter will run the motor and ignore certain trip conditions.



Attention

Although emergency operation meets the functional requirements of the fire mode, how it is applied is not certified and it is not recommended to use emergency operation in situations where testing and / or compliance with specific standards are required.



Be careful

It is not recommended to use emergency operation continuously. Emergency operation may damage the life of the starter because all protections and trips are disabled.

Using the starter in emergency operation mode will void the product warranty.

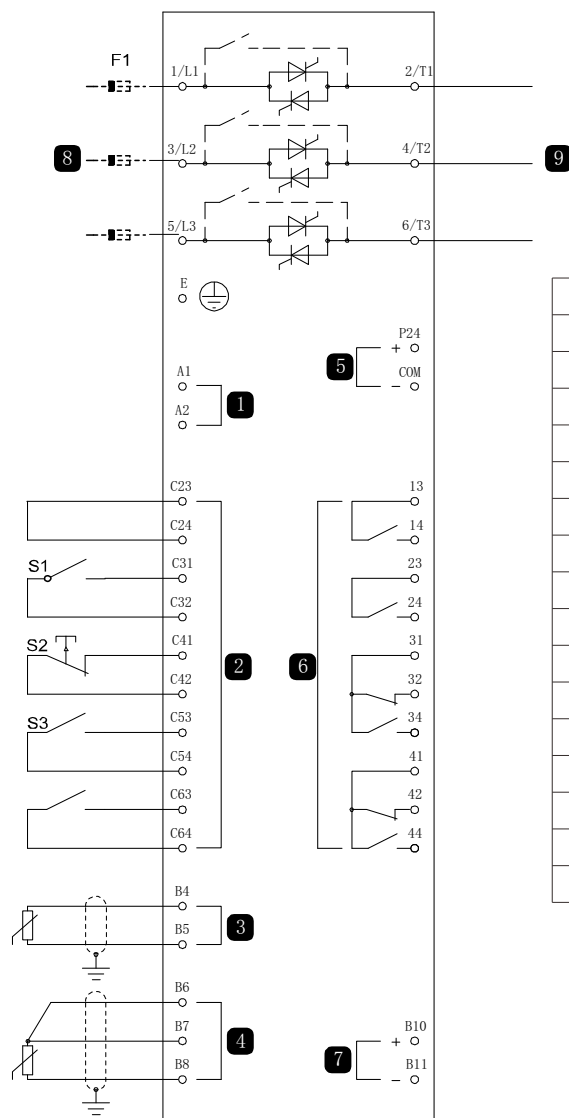

1	Control voltage (depending on model)
2	Remote control input
3	Motor thermistor input
4	RTD / PT100 input
5	24VDC output
6	Relay output
7	Analog output
8	Three-phase power
9	Motor terminal
KM1	Main contactor
F1	Semiconductor fuse (optional)
S1	Start / stop contact
S2	Reset contact
13, 14	Relay output A
23, 24	Run relay output
31, 32, 34	Relay output B
41, 42, 44	Relay output C

Parameter settings:

- Parameter 6A input A function
Select "Emergency Run"-Specify input A for the emergency run function.
- Parameter 15C emergency operation
Select "Enable"-enable emergency running mode. .

10.4 Auxiliary Trip Circuit

During normal operation, the soft starter is controlled by two-wire remote control signals (terminals C31, C32).

Input A (terminals C53, C54) is connected to an external trip circuit (such as the low-voltage alarm switch of a pumping system). When the external circuit is activated, the soft starter trips to stop the motor.

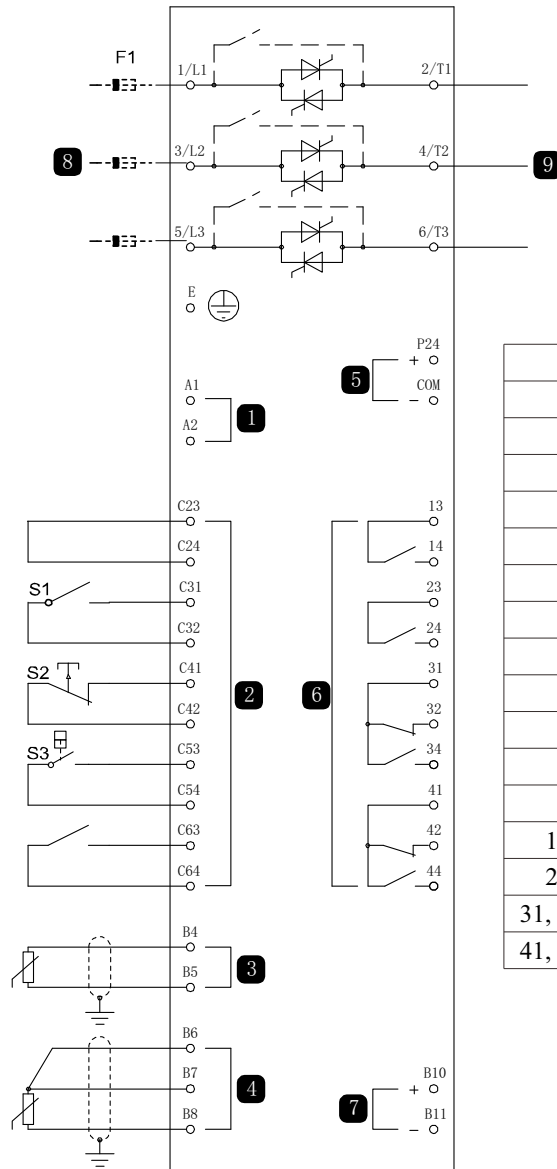

1	Control voltage (depending on model)
2	Remote control input
3	Motor thermistor input
4	RTD / PT100 input
5	24VDC output
6	Relay output
7	Analog output
8	Three-phase power
9	Motor terminal
KM1	Main contactor
F1	Semiconductor fuse (optional)
S1	Start / stop contact
S2	Reset contact
13, 14	Relay output A
23, 24	Run relay output
31, 32, 34	Relay output B
41, 42, 44	Relay output C

Parameter settings:

- Parameter 6A input A function
Select "Input Trip (N / 0)". Assign input A for auxiliary trip (normally open) function
- Parameter 6B enter A name
Select a name, such as "Low Voltage". Specify a name for the input A.
- Parameter 6C input A trip
Set as required. For example, the "Only Run" limit input trip is valid only when the soft starter is running.
- Parameter 6D input A trip delay
Set as required. Set the delay from input activation until the soft starter trips.
- Parameter 6E input A initial delay
Set it to about 120 seconds. Limit the input trip to 120 seconds after the start signal. This way, the pipeline has enough time to increase the water pressure before activating the low pressure input.

10.5 DC Braking With External Zero Speed Sensor

If the load may change during braking, the advantage of using an external zero speed sensor is that the soft starter brake can be turned off. This control method ensures that the soft starter brake is always turned off after the motor is stationary, thereby avoiding unnecessary motor heating.

The following schematic shows how to use the zero speed sensor with a soft starter to turn off the braking function when the motor is stopped. The zero speed sensor (A2) is often called the underspeed detector. Its internal contacts open at zero speed and close when the speed is greater than zero. When the motor reaches the stop state, C53, C54 will be disconnected and the starter will be disabled. After the next start command is issued (ie the next application of Ka1), C53, C54 are closed and the soft starter is enabled.

The soft starter must work in remote mode. Parameter 6A input A function must be set to disable the starter.



Attention

If the braking torque is set too large, the motor will stop before the braking time is over, and the motor generates excessive heat, which may cause damage to the motor. The braking torque must be carefully configured to ensure the safe operation of the starter and motor.

Setting the braking torque too large will cause the peak current to start directly when the motor is stopped. Make sure that the fuses installed in the motor branch circuit are correctly selected.



Attention

The braking operation caused the motor to heat faster than the speed calculated using the motor thermal protection model. If using brake operation, install a motor thermistor or set a sufficiently long restart delay (parameter 4M).

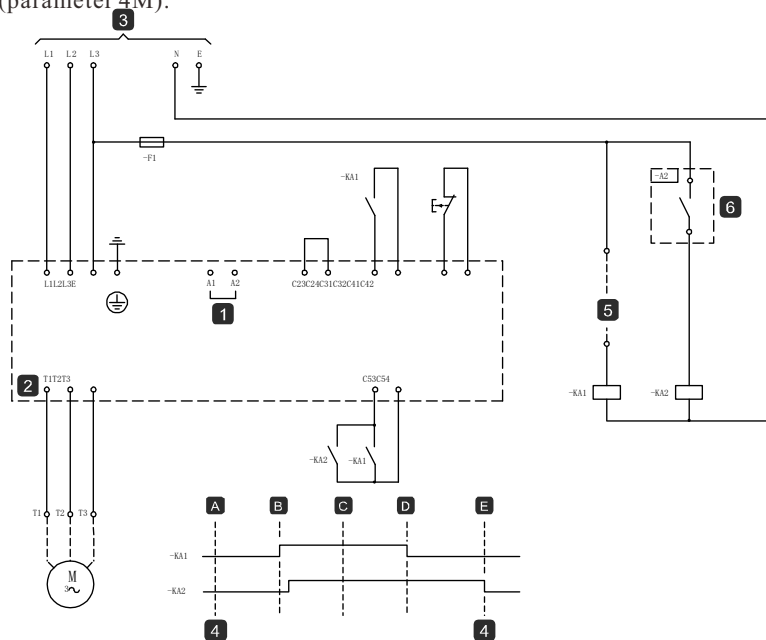

1	Control power
C23, C24	Start
C31, C32	Stop
C41, C42	Reset
C53, C54	Programmable input A (starter disabled)
2	Motor terminal
3	Three-phase power
4	Disable starter (shown on starter screen)

A	Off (ready)
B	Start
C	Run
D	Stop
E	Zero speed
5	Start signal
6	Zero speed sensor

For details on how to configure DC braking, see Braking on page 27.

Be careful

When using DC braking, the power supply and the soft starter (input terminals L1, L2, L3) must be connected in positive phase sequence, and the parameter is 4G. The phase sequence must be set to forward.

Be careful

If the braking torque is set too large, the motor will stop before the braking time is over, and the motor generates excessive heat, which may cause damage to the motor. The braking torque must be carefully configured to ensure the safe operation of the starter and motor.

Setting the braking torque too large will cause the peak current to start directly when the motor is stopped. Ensure that the fuses installed in the motor branch circuit are selected correctly

10.6 Soft Braking

For large inertia load applications and / or variable load applications, a soft starter can be configured for soft braking.

In this application, soft starters are used with forward and brake contactors. When the soft starter receives the start signal (button S1), close the forward rotation

Contactor (KM1), set control motor according to the programmed group motor.

When the soft starter receives the stop signal (button S2), open the forward contactor (KM1), and close the brake contactor (KM2) after a delay of about 2-3 seconds (kt1).

The KA3 is also closed to activate the second set of motor settings programmed by the user for the desired stop performance characteristics.

When the motor speed is close to zero, the zero speed sensor (A2) stops the soft starter and disconnects the brake contactor (KM2).

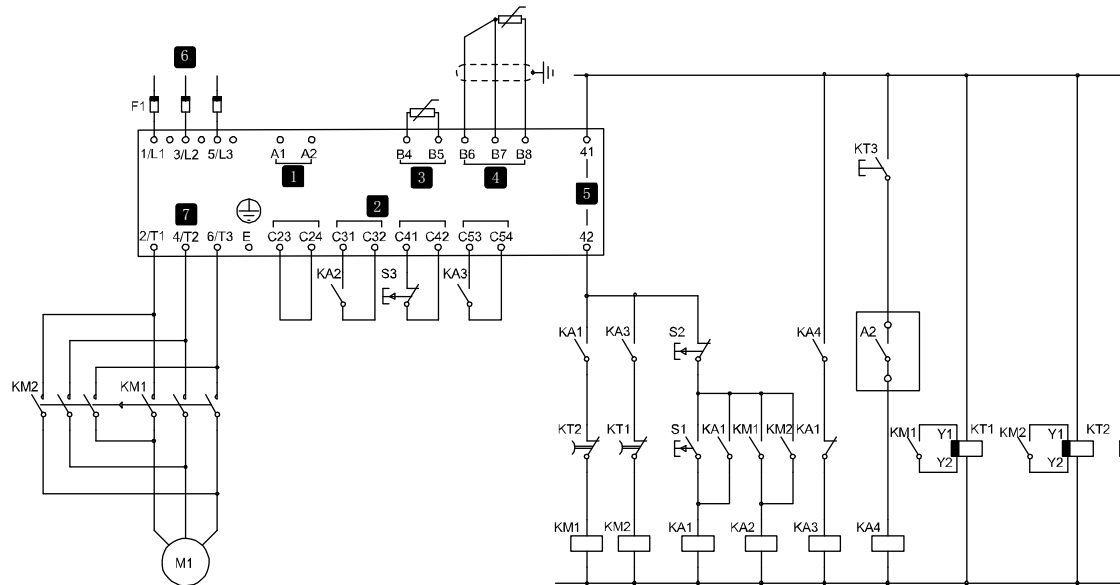

1	Control voltage (depending on model)
2	Remote control input
3	Motor thermistor input
4	RTD / PT100 input
5	Relay output
6	Three-phase power
7	Motor terminal
A2	Zero speed sensor.
F1	Semiconductor fuse (optional)
KA1	Running relay
KA2	Starting relay

KA3	Brake relay
KA4	Zero speed sensing relay
KM1	Line contactor (operation)
KM2	Line contactor (brake)
KT1	Run delay timer
KT2	Braking delay timer
KT3	Zero speed sensing delay relay *.
S1	Starting contact
S2	Stop contact
S3	Reset contact

* The KT3 timer is required only if the zero-speed sensor is a relay type that performs a self-test after power-on and then immediately disconnects the output.

parameter settings:

- Parameter 6A input A function. (Terminals C53, C54)
- Select "Motor parameter selection"-specify input A for motor parameter selection.
- Use the first group of motor parameters to set the starting performance characteristics.
- Use the second set of motor settings to set the braking performance characteristics.
- Parameter 7G relay C function
- Select "Trip"-specify the trip function for relay output C.



Note

If the soft starter trips due to the power frequency (parameter 16F frequency) when the brake contactor KM2 is opened, modify the frequency protection setting.

10.7 Two-speed Motor

High-speed contactor (Km1), low-speed contactor (KM2) and star contactor (KM3) can be used, and a soft starter can be configured for two-speed Dahlander motor control.



Be careful
Pole amplitude modulation (PAM) motors use external winding configuration to effectively change the rotor frequency, thus changing the speed. Soft starters are not suitable for use with such two speed motors.

When the soft starter receives the high-speed start signal, close the high-speed contactor (KM1) and star contactor (KM3), and then set the control motor according to the first group of motors.

When the soft starter receives the low speed start signal, close the low speed contactor (km2). Input a is closed and the soft starter sets the control motor according to the second set of motors.

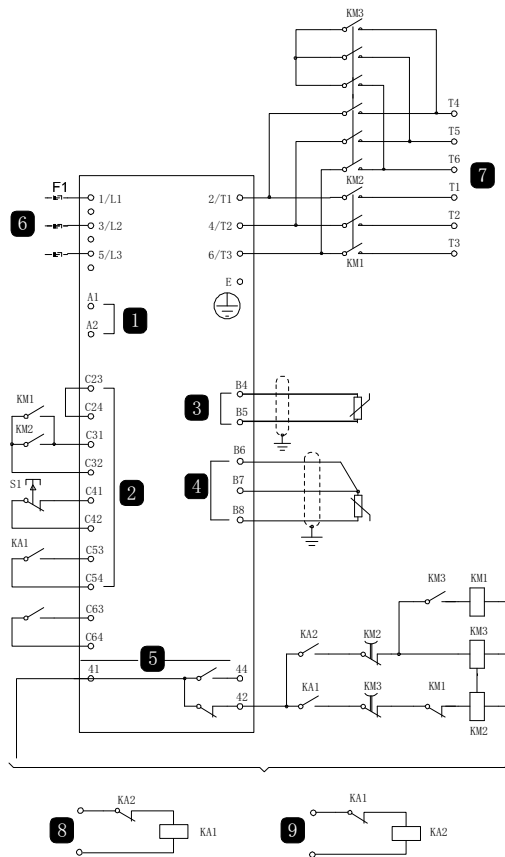

1	Control power
2	Remote control input
3	Motor thermistor input
4	RTD / PT100 input
5	Relay output
6	Three-phase power
7	Motor terminal
8	Remote control low speed start input
9	Remote control high speed start input
F1	Semiconductor fuse (optional)
KA1	Remote start relay (low speed)
KA2	Remote start relay (high speed)
KM1	Line contactor (high speed)
KM2	Line contactor(Low speed)
KM3	Starting contactor (high speed)
S1	Reset contact
41, 42, 44	Relay output C



Be careful
Contactors KM2 and KM3 must be mechanically interlocked.

Parameter setting:

- parameter 6A input a function (terminal C53, C54)
Select "motor parameter selection" one to specify input a for motor parameter selection.
Set the high-speed performance characteristics with the - Group Motor settings.
Use the second set of motor settings to set the low speed performance characteristics.
- parameter 7g relay C function
Select "trip" - specify trip function for relay output C



Attention
If the soft starter trips due to the power frequency (parameter 16F frequency) when the high-speed start signal (9) is disconnected, the frequency protection setting shall be modified.

10.8 Slip Ring Motor

A soft starter can be used to control the slip ring motor using the rotor resistance.

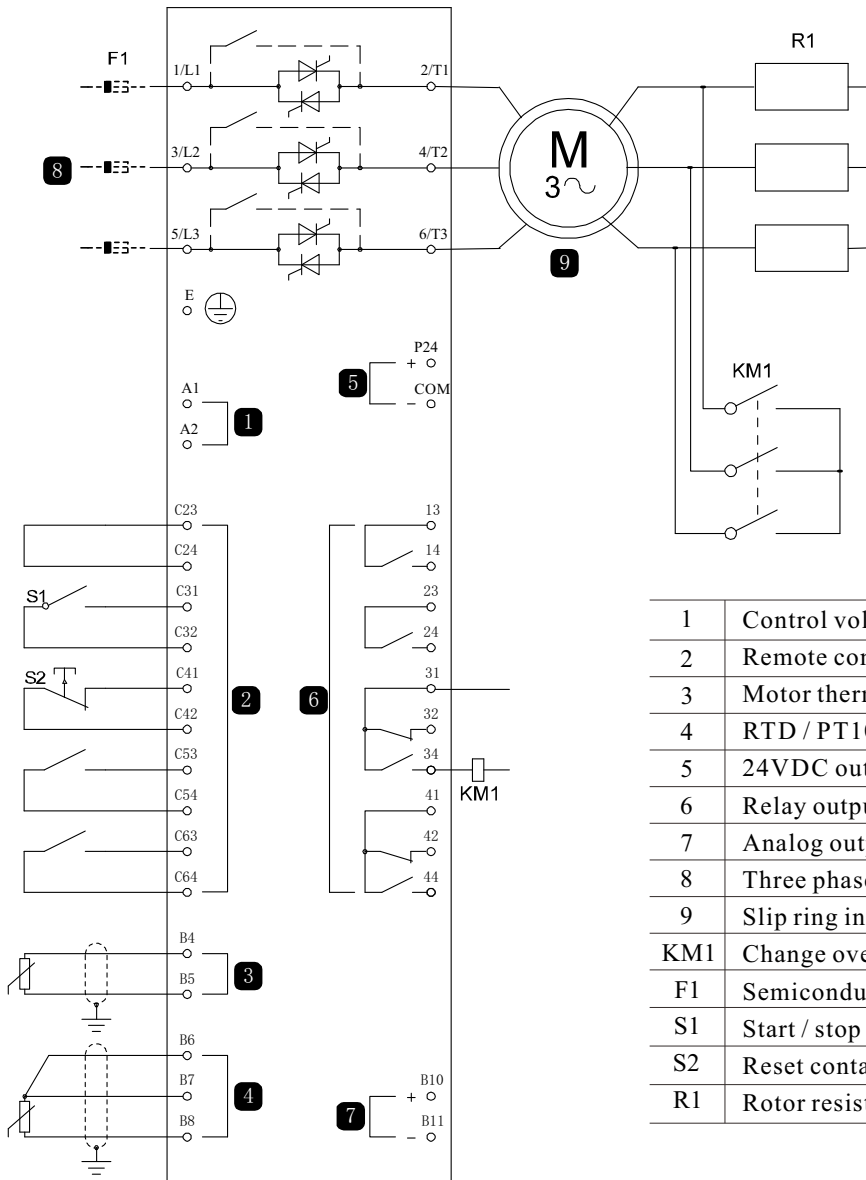

1	Control voltage (depending on model)
2	Remote control input
3	Motor thermistor input
4	RTD / PT100 input
5	24VDC output
6	Relay output
7	Analog output
8	Three phase power supply
9	Slip ring induction motor
KM1	Change over contactor
F1	Semiconductor fuse (optional)
S1	Start / stop contact
S2	Reset contact
R1	Rotor resistance (external)

Debugging

1. Configure the soft starter as follows:

Parameter setting: parameter 7d relay B function

Select 'change over contactor'

- parameter 7e relay B open delay

Set this parameter to the maximum time (5 minutes: 00 seconds).

- parameter 12a motor data 1 ramp

Select 'double slope' (for slip ring induction motor control)

- parameter 12C conversion time

The default setting is 150 milliseconds. Set this value to a value greater than the phase closing time of the change-over contactor (KM1).

- valuepoint 12D slip ring reduction

The default setting is 50%. Set this parameter large enough to allow the motor to accelerate immediately after the rotor resistance (R1) is bypassed, if set Small enough to avoid motor current pulse.

2. Start the motor under normal load and record the time required for the motor to reach a constant speed when the circuit has external rotor resistance (R1).

Stop the motor as soon as it reaches a constant speed. Change parameter 7e to the recorded time value.

3. Start the motor under normal load conditions and monitor the speed characteristics and motor current of the motor after the switching contactor (KM1) is switched and the stator resistance (R1) is shorted.
 If the motor does not accelerate immediately after the conversion, increase the setting of parameter 12D.
 If the motor current changes abruptly after the conversion, the setting of parameter 12D needs to be reduced.

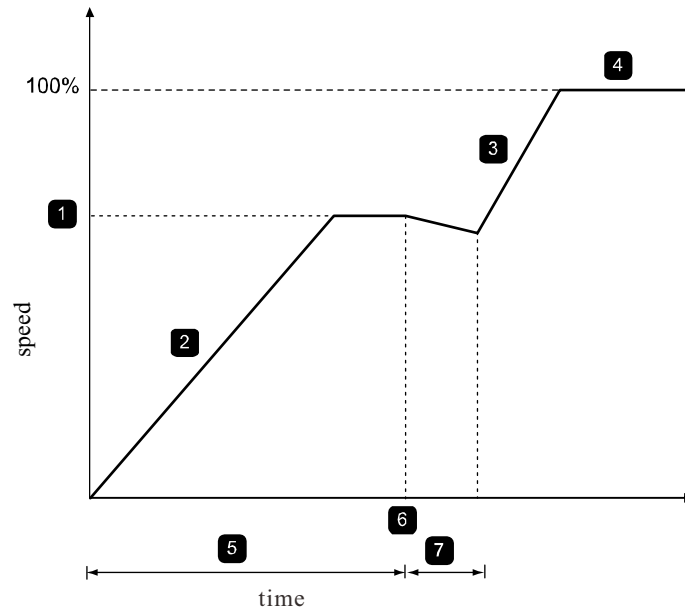

1	R1 constant speed
2	First slope
3	Second slope
4	Operating mode ($I < 120\%$ of motor rated current)

5	Parameter 7E Relay B Open Delay
6	KM1 closed
7	Parameter 12C conversion time



Note

In order for this device to work properly, only the motor settings of group-are used. Use only constant current starting method (parameter 2A starting method).

Chapter 11 Fault Resolution

11.1 Protection Response

When a protection condition is detected, the soft starter writes the protection condition to the event log. It may trip and may issue a warning. The soft starter response depends on the protective measures setting (parameter setting 16).

The user cannot adjust one or more of the protection responses. These trips are usually caused by external events (such as phase loss), or they may be caused by internal faults of the soft starter. These trips have no related parameters and cannot be set as warnings or logs.



If the soft starter trips, you need to identify and clear the conditions that triggered the trip, reset the soft starter, and then restart. To reset the starter, press the RESET button on the control panel-or activate the "Reset remote input".



If the soft starter alarms, the soft starter will reset automatically after the cause of the alarm is eliminated.

11.2 Trip Message

The following table lists the protection mechanisms and possible trip causes of the soft starter. Some settings can be adjusted with parameter settings 4 protection settings and parameter settings 16 protection measures, while other settings are built-in system protection and cannot be set or adjusted.

Display	Possible cause / suggested solution
Analog input trip	Determine and exclude activation conditions for analog input A. Related parameters: 6N, 6O, 6P
Waiting for data	The operation board did not receive data from the control PCB. Check that the cables on the starter are properly connected and installed.
Battery / clock	A real-time clock verification error has occurred, or the backup battery voltage is too low. If the battery voltage is too low and the power is off, the date / time setting will be lost. Reset the clock. Related parameters: 16M
Controller	This is the name chosen for the programmable input. See Input Trip.
Current imbalance	Current imbalances can be caused by motor problems, environmental problems, or installation problems, such as: <ul style="list-style-type: none"> ● Unbalanced supply voltage ● Motor winding problem ● Small motor load ● Input terminals L1, L2, or L3 lack phase in operating mode The thyristor has an open circuit. Only by replacing the thyristor and checking the performance of the starter can the diagnosis be clearly determined. Whether the thyristor is malfunctioning. Related parameters: 4H, 4I, 16E
Current read error LX	Where X is 1, 2 or 3. Internal fault (PCB failure). When the thyristor power is cut off, the current transformer circuit output does not reach zero. Contact your local supplier for advice. This trip cannot be adjusted. Related parameters: None
Starting limit time	Trip limit time trips can occur in the following situations: <ul style="list-style-type: none"> ● Parameter 1A motor rated current is not suitable for this motor ● The parameter 2D current limit is set too small ● Parameter 2B start ramp time is set to be larger than the 4A setting start limit time ● Parameter 2B The starting ramp time is set too short, it is not suitable for large inertia loads when using adaptive control Related parameters: 1A, 2B, 2D, 4A, 4B, 9B, 10B, 10D, 16B
Trigger failed PX	Where X is phase 1, phase 2, or phase 3. The thyristor does not trigger as expected. The thyristor may be malfunctioning, or the internal wiring may be malfunctioning. This trip cannot be adjusted. Related parameters: None
Excessive rated current (Rated current is out of range)	This trip cannot be adjusted. If the soft starter uses a delta connection instead of a star connection to connect the motor, it can support larger motor rated current values. If the soft starter is connected using the star connection method, but the programmed setting of parameter 1A motor rated current exceeds the maximum value of the star connection method, the soft starter will trip when starting (see Minimum and Maximum Current Setting on page 71). If the soft starter is connected to the motor using a delta connection method, the soft starter may not detect the connection correctly. Contact your local supplier for advice. Related parameters: 1A and 9B



Display	Possible cause / suggested solution
Frequency (power)	<p>This trip cannot be adjusted. The power frequency is outside the specified range. Check whether other equipment in this range affects the power supply, especially variable speed drives and switching power supplies. If the soft starter is connected to a generator set, the generator may be too small, or there may be speed regulation problems. Related parameters: 4J, 4K, 4L, 16F</p>
Ground fault	<p>This fault occurs only when an RTD / ground fault card is installed. Test output cable insulation and motor insulation. Identify and eliminate any ground fault cause. Related parameters: 40, 4P, 16N</p>
Radiator overheating	<p>Check if the cooling fan is working. If installed in a cabinet, check for adequate ventilation. During the starter's start and operation, the fan works and continues to work for 10 minutes after the starter enters the stopped state.</p> <p> Note Models 0023B to 0053B and 0170B do not have cooling fans. For models with a cooling fan, the fan is turned on at startup and turned off after 10 minutes of inactivity. Related parameters: 16L</p>
High level	This is the name chosen for the programmable input. See Input Trip.
High pressure	This is the name chosen for the programmable input. See Input Trip.
Input Trip	<p>One of the inputs of the soft starter is set to the trip function and is activated. Check the input status to determine which input is active, and then exclude the trigger condition. Related parameters: 6A, 6B, 6C, 6D, 6E, 6F, 6G, 6H, 6I, 6J, 16G, 16H</p>
Instantaneous Overcurrent	<p>The soft starter reports this trip when any of the following conditions occur: The motor power increases sharply. Causes may include transient overload conditions exceeding an adjustable delay. Related parameters: 2U, 2V, 16P The current through the motor exceeds the built-in trip point of the soft starter. 7.2 times of parameter 1A <i>Motor rated current</i> 6 times the starter current rating Causes of transient overcurrent include locked rotors, or a malfunction of the motor or wiring. This trip cannot be adjusted. Related parameters: None</p>
Internal fault X	<p>This trip cannot be adjusted. The soft starter has tripped due to an internal fault. Contact your local supplier for the meaning of fault code (X). Related parameters: None</p>
L1 Phase Loss L2 Phase Loss L3 Phase Loss	<p>This trip cannot be adjusted. Before starting, check whether the starter has detected and displayed a phase loss. In the running state, the starter detects that the current of the affected phase has dropped below 2% of the programmed motor's rated current, and the duration exceeds 1 second, which indicates that the phase on the line side is missing or the connection to the motor is disconnected. Check the power, input and output connections of the starter and the motor. Failure of thyristor, especially open circuit of thyristor, will also cause phase loss. Only by replacing the thyristor and checking the performance of the starter, can the diagnosis of the thyristor fail clearly. Related parameters: None</p>
L1-t1 Short L2-t2 Short L3-t3 Short	<p>Before starting, check whether the starter detects and displays a short circuit of the thyristor or an internal short circuit of the bypass contactor. If the starter is connected to the motor using a star connection method, consider using a two-phase control method to keep the starter working until the starter can be repaired.</p> <p> Note Only motors connected by star connection support two-phase control. If the soft starter is connected using a delta connection method, two-phase control does not work. The next time the control power is applied, the starter will trip due to an Lx-Tx short circuit. If the control power is turned on again between two starts, the two-phase control does not work. Related parameters: 15D</p>

Display	Possible cause / suggested solution
Low control voltage	<p>The soft starter has detected a drop in the control voltage.</p> <ul style="list-style-type: none"> ● Check external control power (terminals A1, A2, A3) and reset the starter. <p>If external control power is stable:</p> <ul style="list-style-type: none"> ● It may be that the 24V power supply on the main control PCB is faulty, or the bypass drive PCB may be faulty (only the internal bypass type). Contact your local supplier for advice. <p>In the ready state, this protection is not activated. Related parameters: 16X</p>
Low level	This is the name chosen for the programmable input. See Input Trip.
Low pressure	This is the name chosen for the programmable input. See Input Trip.
Motor overload (thermal model)	<p>The motor has reached its maximum thermal capacity. Overload may be caused by:</p> <ul style="list-style-type: none"> ● Soft starter protection setting does not match the thermal capacity of the motor ● Too many starts per hour ● The output is too large ● Damaged motor windings <p>Remove the cause of the overload and allow the motor to cool Related parameters: 1A, 1B, 1C, 1D, 16A</p> <p> Attention Parameters 1B, 1C and 1D determine the trip current of the motor overload protection. The default settings of parameters 1B, 1C and 1D provide motor overload protection: level 10, trip current, FLA (rated current) 105% or equivalent.</p>
Motor 2 overload	<p> Refer to Motor Overload (Thermal Model) above. Attention Only applicable after programming the second group of motors. Related parameters: 9A, 9B, 9C, 9D, 9E, 16A</p>
Motor connection TX	<p>Where X is 1, 2 or 3. The motor is connected to the soft starter using a star connection or delta connection method.</p> <ul style="list-style-type: none"> ● Check each connection between the motor and soft starter to see if the power supply circuit is unblocked. ● Check the connections on the motor terminal box. <p>This trip cannot be adjusted. Related parameters: None</p>
Motor thermistor	<ul style="list-style-type: none"> ● The motor thermistor input is enabled and the resistance of the thermistor input exceeds 3.6 kΩ for more than 1 second. ● Motor winding is overheating. Determine the cause of overheating, allow the motor to cool, and then restart the motor. ● The motor thermistor input is turned on. <p> Attention If an effective motor thermistor is no longer used, a 1.2kΩ resistor must be connected between terminals B4 and B5. Related parameters: 16I</p>
Network communication (between interface and network)	<p>The network master has sent a trip command to the starter, or there is a problem with the network communication. Examine the cause of communication problems on the network. Related parameters: 16K</p>
No traffic	This is the name chosen for the programmable input. See Input Trip.
Not ready	<p>Check input A (C53, C54). It is possible to disable the starter via a programmable input. If parameter 6A or 6F is set to disable the starter and there is an open circuit on the corresponding input, the soft starter will not start.</p>
Parameter is out of range	<p>This trip cannot be adjusted.</p> <ul style="list-style-type: none"> ● The parameter value is outside the valid range. <p>The operator panel will display the first invalid parameter.</p> <ul style="list-style-type: none"> ● An error occurred while loading the data from the EEPROM into the RAM after the operation board was powered on. ● The parameter setting or actual value on the operation panel does not match the starter parameters. ● "Load user settings" was selected, but no saved files are available. <p>Reset fault. The starter will load the default settings. If the problem persists, contact your local dealer. Related parameters: None</p>

Display	Possible cause / suggested solution
Phase sequence	The phase sequence on the soft starter input terminals (L1, L2, L3). Is incorrect. Check the phase sequence on L1, L2, L3. Make sure the setting in parameter 4G is suitable for the device. Related parameters: 4G
PLC	This is the name chosen for the programmable input. See Input Trip.
Power-down / power circuit	This trip cannot be adjusted. When a start command is issued, one or more phases of the starter are not energized. Check whether the main contactor is closed when the start command is issued and whether it is closed until the soft stop is completed. Check the fuse. If the soft starter is tested with a small motor, at least 2% of the minimum rated current must flow through each phase. Related parameters: None
Pump failure	This is the name chosen for the programmable input. See Input Trip.
RTD A overheated to RTD 6 overheated.	Above the RTD / PT100 set temperature, the soft starter trips. Identify and exclude activation conditions for the corresponding inputs. <div style="display: flex; align-items: center;"> <div style="border: 1px solid black; padding: 2px; margin-right: 10px;"> <p style="margin: 0;">Attention</p> </div> <p>Pt100 B ~ PT100 G can only be used after RTD / PT100 and ground fault card are installed. Related parameters: 11A, 11B, 11C, 11D, 11E, 11F, 11G, 16O ~ 16U</p> </div>
RTD circuit failure	The displayed RTD / PT100 has a short circuit. Check and exclude this condition. Related parameters: none
Starter communication (connect Port and soft starter)	There is a problem with the connection between the soft starter and the optional communication interface. Remove the interface and reinstall it. If the problem persists, contact your local dealer. The soft starter has an internal communication error. Contact your local dealer. Related parameters: 16J
Disable starter	This is the name chosen for the programmable input. See Input Trip.
Thermistor circuit	The thermistor input is enabled, and: <ul style="list-style-type: none"> ● The input resistance is less than 20 Ω (the cold resistance of most thermistors is greater than this value), or a short circuit has occurred. Check and exclude this condition. Related parameters: none
Time limit overcurrent	The soft starter has a built-in bypass and requires a large current during operation. (When the protection curve of 10A is tripped, or the motor current rises to 600% of the motor rated current setting value.) Related parameters: none
Under current	The motor current drops sharply, which is caused by unloading. Causes of descent include broken components (shafts, belts, or couplings), or the pump is idling. Related parameters: 4C, 4D, 16C
Unsupported option (Triangle connection method (This feature is not supported))	This trip cannot be adjusted. The selected function cannot be used (for example, the triangle connection method does not support jog). Related parameters: None
Vibration alarm	This is the name chosen for the programmable input. See Input Trip.
VZC failure PX	Where X is 1, 2 or 3. Internal fault (PCB failure). Contact your local supplier for advice. This trip cannot be adjusted Related parameters: None

11.3 General faults

The following table describes known soft starter failures without tripping or warning.

Symptom	Possible reason
Starter "Not Ready"	Check input A (C53, C54). It is possible to disable the starter via a programmable input. If you participate The number 6A or 6F is set to starter disabled and the corresponding input. If there is an open circuit, the soft starter will not start.
The soft starter does not respond to START or RESET on the operation panel.	The soft starter may be in remote control mode. When the soft starter is in remote mode, The local LED on the actuator does not light up. Press the L / R (local / remote) button once to switch to local control.
The soft starter does not respond to commands from the control inputs.	The soft starter may be in local control mode. When the soft starter is in local control mode, The local LED on the starter is on. Press the L / R (local / remote) button once to switch to Local control. The control cable may be connected incorrectly. Check remote control start input, remote control stop input And remote control reset input are configured correctly (see Control Cables on page 6 for details) The signal sent to the remote control input may be wrong. Activate each input signal in turn and test. input signal. The corresponding remote control input LED on the starter should be on.
The soft starter does not respond to start commands from local control or over-control.	The soft starter may be waiting for the restart delay to elapse. Restart delay length is subject to parameters 4M restart delay control. The motor may be too hot to start. If parameter 4N Motor Temperature Measurement is set to Measure Only when the soft starter calculates that the motor has sufficient thermal capacity to successfully complete the start, The soft starter is allowed to start. Wait for the motor to cool down before attempting to start. It is possible to disable the starter via a programmable input. If parameter 6A or 6F is set as starter disabled If there is an open circuit on the corresponding input, the soft starter will not start. If no longer needed Disable the starter and close the input circuit.  Note Parameter 6Q Local / Remote: Controls when the L / R (local / remote) button is enabled.
When using two-wire remote control, reset is not performed after automatic reset.	The two-wire remote control start signal must be canceled, and then the start signal reapplied to restart.
When using two-wire remote control, the remote start / stop command overrides the automatic start / stop setting.	The auto start / auto stop function can only be used in remote mode with three or four wire control.
If there is a connection between the thermistor inputs B4 and B5, or if the motor thermistor between B4 and B5 is permanently removed, a non-resettable thermistor circuit will trip.	After establishing the connection and activating the short-circuit protection, enable the thermistor input. Remove the connection and load the default parameter group. This will disable the thermistor input and clear the trip. Connect a 1k2 to the thermistor input Set the thermistor protection to "record only" (parameter 16I).
When using two-wire remote control, the remote start / stop command overrides the automatic start / stop setting.	The auto start / auto stop function can only be used in remote mode with three or four wire control.
The soft starter cannot control the motor correctly during the starting process.	If a small motor rated current setting (parameter 1a) is used, the starting performance may be unstable. This may affect the use of soft starters on small test motors rated from 5 A to 50 A. A power factor correction capacitor must be connected at the power supply end of the soft starter. To control dedicated The power factor correction capacitor contactor connects the contactor to the operation relay terminal.
The motor cannot reach full speed.	If the starting current is too small, the motor cannot produce enough torque to accelerate to full speed. The soft starter may trip due to the starting limit time.  Be careful Ensure that the motor starting parameters are suitable for the application and use the expected motor starting curve. If parameter 6A or 6F is set as motor parameter selection, check whether the corresponding input is in the expected state. The load may be blocked. Check whether the load is seriously overloaded and whether the rotor is locked.
Motor operation is unstable.	The thyristor in the soft starter must have a current of at least 5A to be locked. If the rated current is less than When testing the soft starter on the motor of 5A, the thyristor may not lock normally.

<p>The motor is irregular or noisy.</p>	<p>If the soft starter is connected to the motor by triangle connection method, the soft starter may not be inspected correctly Test connection. Contact your local supplier for advice.</p>
<p>Soft stop ends too fast.</p>	<p>The soft stop setting may not be appropriate for the motor and load. Check the settings of parameters 2h, 2I, 10h and 10I. If the load of the motor is very small, the function of soft stop is very limited.</p>
<p>Adaptive control, braking, inching and two-phase control functions do not work.</p>	<p>These functions can only be used with star connection. If the soft starter is connected with triangle connection method, these functions will not work.</p>
<p>After the adaptive control is selected, the motor is started normally, and the second start is different from the first start.</p>	<p>The first adaptive control start is a real constant current so that the starter can understand the motor characteristics. Adaptive control is used for subsequent starting.</p>
<p>When this option is selected, two-phase control does not work.</p>	<p>The next time control power is applied, the starter will trip due to Lx-Tx short circuit. If the control power is switched on again between two starts, the two-phase control will not work.</p>
<p>Starter "waiting for data</p>	<p>The operation board did not receive data from the control PCB. Check the cable of the display on the starter Whether the connection and installation are correct.</p>
<p>The display of the operation panel is in disorder.</p>	<p>The fixing screws of the operation board may not be tightened, causing intermittent connection. Tighten the operation panel Fix the screws or install the four corners in place.</p>
<p>Display distortion</p>	<p>Check whether the fixing screws of the operation board are tightened too tightly. Loosen the screws slightly.</p>
<p>Unable to save parameter settings.</p>	<p>Make sure that after adjusting the parameter settings, press the menu (store) button to save the new values. If you press exit(exit), changes are not saved. Check whether the parameter write protection (parameter 15b) is set to read-write. If parameter write protection is set If it is read-only, you can view the parameters, but you cannot change them. You must enter the security access password To change parameter write protection settings. EEPROM on operation panel. May be faulty. Failure of EEPROM will also cause soft starter Trip, and an error message will be displayed on the operation panel: parameter out of range. Contact local supplier Ask for advice.</p>
<p>Attention! Cut off the main power supply</p>	<p>If the three-phase power supply is connected, the soft starter will not activate the operation simulation. This can prevent accidents Trigger direct start.</p>

Chapter 12 Appendix

12.1 Specifications

Model code

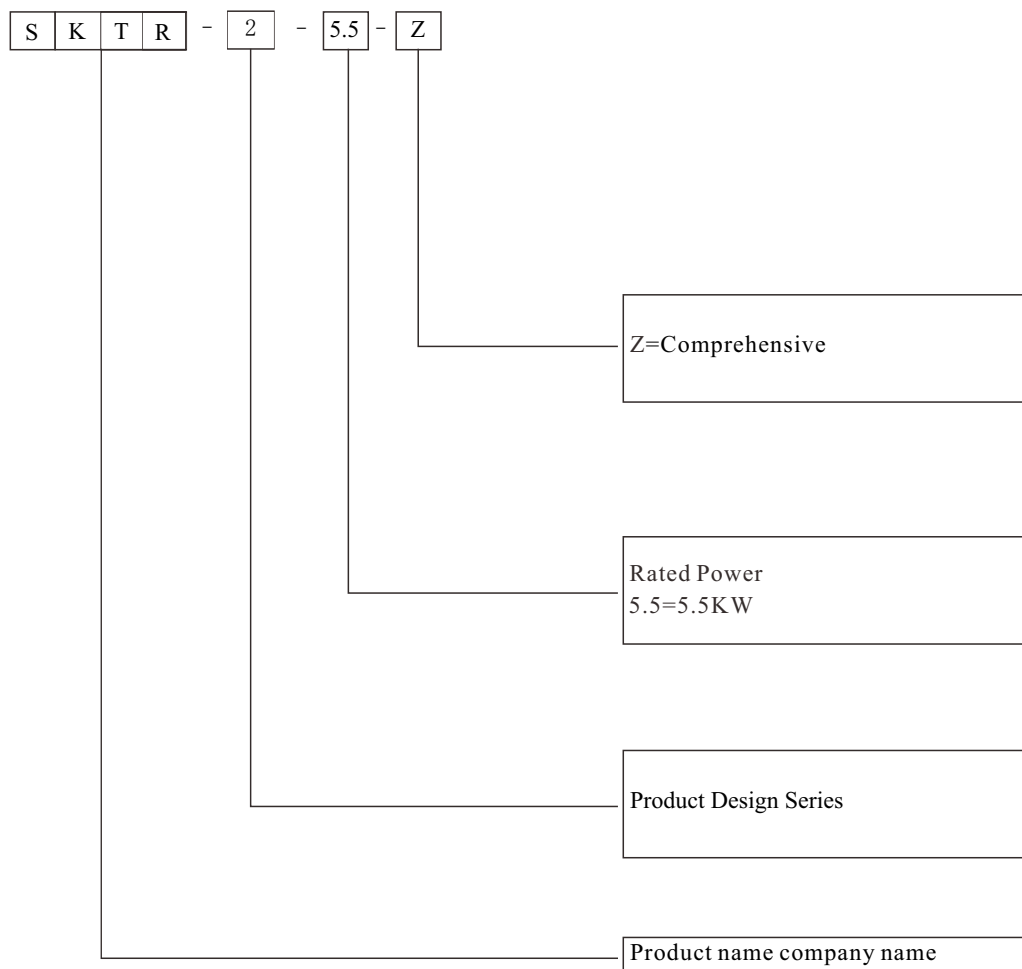

Minimum and maximum current settings

The minimum rated current setting and the maximum rated current setting of the soft starter depend on the model:

Model	Star connection method	Rated current of delta connection method
SKTR2-5.5-Z	11A	16A
SKTR2-7.5-Z	15A	22A
SKTR2-011-Z	23A	34A
SKTR2-015-Z	30A	44A
SKTR2-018-Z	37A	55A
SKTR2-022-Z	45A	67A
SKTR2-030-Z	60A	89A
SKTR2-037-Z	75A	111A
SKTR2-045-Z	90A	133A
SKTR2-055-Z	110A	163A
SKTR2-075-Z	150A	222A
SKTR2-090-Z	180A	266A
SKTR2-110-Z	220A	325A
SKTR2-132-Z	255A	377A
SKTR2-160-Z	320A	474A
SKTR2-185-Z	370A	548A
SKTR2-200-Z	400A	592A
SKTR2-220-Z	425A	629A
SKTR2-250-Z	500A	740A
SKTR2-280-Z	560A	829A
SKTR2-320-Z	630A	932A
SKTR2-350-Z	700A	1036A
SKTR2-400-Z	800A	1184A
SKTR2-450-Z	900A	1332A
SKTR2-500-Z	1000A	1480A

Size and weight

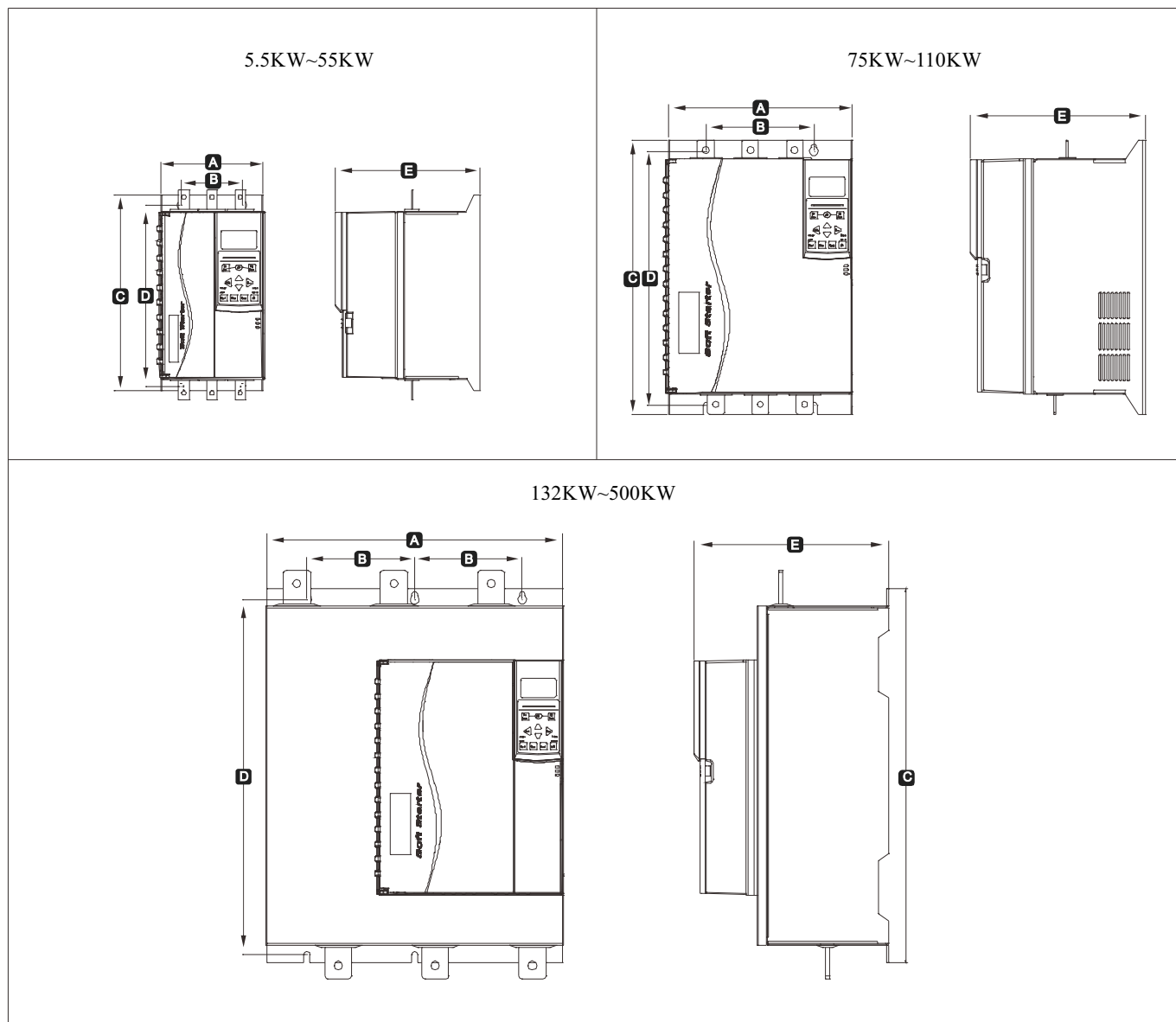

Model	A mm	B mm	C mm	D mm	E mm	F mm	G mm	H mm	Weight kg
5.5KW~55KW	152	92	292	269	215	Not applicable	Not applicable	Not applicable	5.2
75KW~110KW	274	160	408	385	260	Not applicable	Not applicable	Not applicable	17.5
132KW~500KW	440	320 (160*2)	530	530	290	Not applicable	Not applicable	Not applicable	35.5

12.2 parameter value

If you need the assistance of the supplier or service technician, please fill in all parameter settings in the table below.

1	Motor data - 1	User settings 1	User settings 2
1A	Rated current of motor		
1B	Locked rotor time		
1C	Locked rotor current		
1D	Service factor of motor		
2	Start / stop MODE-1		
2A	Starting mode		
2B	Starting ramp time		
2C	Initial current		
2D	Current limit		
2E	Adaptive starting curve		
2F	Jump start time		
2G	Jump start amplitude		
2H	Stop mode		
2I	Stopping time		
2J	Adaptive stop curve		
2K	Adaptive control gain		
2L	Braking torque		
2M	Braking time		
3	Auto start / stop		
3A	Auto start mode		
3B	Auto start time		
3C	Automatic stop mode		
3D	Auto stop time		
4	Protection settings		
4A	Starting limit time		
4B	Starting limit Time-2		
4C	Undercurrent		
4D	Under current delay		
4E	Instantaneous overcurrent		
4F	Instantaneous overcurrent delay I		
4G	Phase sequence		
4H	Current imbalance		
4I	Current unbalance delay		
4J	frequency measurement		
4K	Frequency variation		
4L	Frequency delay		
4M	Restart delay		
4N	Motor temperature measurement		
4O	Earth fault current		
4P	Earth fault delay		
4Q	Retain		
4R	Retain		
4S	Retain		
4T	Retain		
5	Automatic reset trip		
5A	Automatic reset function		
5B	Maximum reset times		
5C	A / b reset delay		
5D	C reset delay		

6	Input		
6A	Input a function		
6B	Enter a name		
6C	Input a trip		
6D	Input a trip delay		
6E	Input a initial delay		
6F	Input b function		
6G	Enter b name		
6H	Input b trip		
6I	Input b trip delay		
6J	Input b initial delay		
6K	Input c function		
6L	Input d function		
6M	Remote reset logic		
6N	Analog input trip		
6O	Analog input range		
6P	Simulated trip point		
6Q	Local / remote:		
6R	Remote control communication		
7	Output		
7A	Relay a function		
7B	Relay a opening delay		
7C	Relay a off delay		
7D	Relay b function		
7E	Relay b on delay		
7F	Relay b off delay		
7G	Relay c function		
7H	Relay c on delay		
7I	Relay c off delay		
7J	Relay d function		
7K	Relay e function		
7L	Relay f function		
7M	Low current indication		
7N	High current indication		
7O	Motor temperature indication		
7P	Analog output a		
7Q	Analog a range		
7R	Analog a max		
7S	Analog a min		
7T	Analog output B		
7U	Analog B range		
7V	Analog B Max		
7W	Analog B min		
8	monitor		
8A	language		
8B	F1 button function		
8C	F2 button function		
8D	Display current or power		
8E	Top left corner of screen		
8F	Top right corner of screen		

8G	Bottom left corner of screen		
8H	Bottom right corner of screen		
8I	Graphic data		
8J	Graphic display period		
8K	Graphic display maximum		
8L	Graphic display minimum		
8M	Current calibration		
8N	Main supply voltage		
8O	Voltage calibration		
9	Motor data-2		
9A	Double thermal protection model		
9B	Motor rated current - 2		
9C	Locked rotor time-2		
9D	Locked rotor current-2		
9E	Motor service factor-2		
10	Start / stop mode-2		
10A	Starting mode-2		
10B	Starting ramp-2		
10C	Initial current - 2		
10D	Current limit-2		
10E	Adaptive starting curve-2		
10F	Jump start time-2		
10G	Jump start amplitude-2		
10H	Stop mode-2		
10I	Stop time-2		
10J	Adaptive stop curve-2		
10K	Adaptive control gain 2		
10L	Brake torque-2		
10M	Braking Time-2		
11	RTD temperature		
11A	<i>RTD/PT100 A°C</i>		
11B	<i>RTD/PT100 B°C</i>		
11C	<i>RTD/PT100 C°C</i>		
11D	<i>RTD/PT100 D°C</i>		
11E	<i>RTD/PT100 E°C</i>		
11F	<i>RTD/PT100 F°C</i>		
11G	<i>RTD/PT100 G°C</i>		
12	Slip ring motor		
12A	Motor data 1 ramp		
12B	Motor data 2 ramp		
12C	Conversion time		
12D	Slip ring reduction		
15	Senior		
15A	Access code		
15B	Parameter write protection		
15C	Emergency operation		
15D	Short circuit thyristor action		
16	Protective measures		
16A	Motor overload		
16B	Starting limit time		
16C	Undercurrent		

16D	Instantaneous overcurrent		
16E	Current imbalance		
16F	Frequency		
16G	Input a trip		
16H	Input b trip		
16I	Motor thermistor		
16J	Starter communication		
16K	Network communication failure		
16L	Heatsink ot		
16M	Battery / clock failure		
16N	Grounding fault		
16O	<i>RTD/PT100 A</i>		
16P	<i>RTD/PT100 B</i>		
16Q	<i>RTD/PT100 C</i>		
16R	<i>RTD/PT100 D</i>		
16S	<i>RTD/PT100 E</i>		
16T	<i>RTD/PT100 F</i>		
16U	<i>RTD/PT100 G</i>		
16V	Retain		
16W	Retain		
16X	Low control voltage		
20	limit		

Chapter 13 MODBUS user manual

13.1 Important usage information

When remotely controlling the soft starter, all necessary safety precautions should be taken. Warn others that the machine may be at any time start.

The installer must follow all instructions in this manual and follow the corresponding electrical installation practices.

When installing and using RS-485 equipment, observe the internationally accepted RS-485 communication standard.

13.2 Setting

Protocol, address setting

1. Communication address: set by DIP switch
2. Baud rate: 9600bps;
3. Protocol: Only RTU mode can be used;
4. The communication format is fixed as 8:N:1

13.3 Modbus function

The Modbus interface supports the following Modbus functions:

- 03 Read multiple registers.
- 06 Write to a register.

Does not support Modbus broadcast function

Read address:

- Read multiple registers 40003 to 40008.
- Write a register 40002.
- Read and write multiple registers 40009 to 40599.
(40009 address corresponds to the extended menu 1A,
40010 corresponds to 1B, Successively)
- A single write register 40002 or multiple write registers
40600 to 40631.

13.4 Modbus Register

All registers can be read / written multiple times (unless otherwise stated).

Register	Explanation	Bit	Details
40002	command (Write once)	0 to 2 3 to 7	Send the command to the starter and write the required value: 1 = start 2 = stop 3 = Reset 4 = Quick stop (coast stop) 5 = Forced communication trip 6 = Start with parameter 1 7 = Start with parameter 2 save
40003	Starter status	0 to 3	1 = ready 2 = start 3 = run 4 = Stop (including braking) 5 = Restart delay (including temperature check) 6 = trip 7 = programming mode 8 = Jog forward 9 = Jog reverse
		4	1 = Positive phase rotation (only valid when bit 6 = 1)
		5	1 = Current exceeds rated current
		6	0 = Not initialized 1 = initialization
		7	0 = Remote control communication is normal 1 = Remote control / communication equipment malfunction
40004	Trip code	0 to 7	See trip code page 8
40005 ²	Motor current	0 to 7	Three-phase motor average current (A)
40006	Motor temperature	0 to 7	Motor 1 temperature (thermal model)
40007	product information	0 to 2	Product parameter list version
		3 to 7	Product type code
40008	Serial protocol version	0 to 7	
40009 ⁴	Parameter management One / multiple read or write	0 to 7	Manage soft starter programmable parameters.
40600	Version	0 to 5 6 to 8 9 to 15	Binary protocol version number Parameter list version number Product type code
40601	Save		
40602 ⁵	Changed parameter number	0 to 7 8 to 15	0 = parameter has not changed 1 to 255 = index number of the last parameter changed The total number of parameters available in the launcher
40603 ⁵	Changed parameter value	0 to 13	The value of the last changed parameter (same value as indicated in register 40602)
		14 to 15	Save

Register	Explanation	Bit	Details
40604	Starter status	0 to 4	0 = reserved 1 = ready 2 = start 3 = run 4 = stop 5 = Not ready (restart delay, restart temperature measurement, run simulation) 6 = trip 7 = programming mode 8 = Jog forward 9 = Jog reverse
		5	1 = warning
		6	0 = not initialized 1 = initialized
		7	0 = local control 1 = Remote control
		8	0 = Starting from the last parameter read, the parameter has been changed 1 = parameter has not changed
		9	0 = negative phase sequence 1 = positive phase sequence
		10 to 15	See Trip Code Page 8
40605 ²	Current	0 to 13 14 to 15	Average root mean square current of all three phases Save
40606	Current	0 to 9 10 to 15	Current (percentage of motor rated current) Save
40607	Motor temperature	0 to 7 8 to 15	Motor 1 thermal model (%) Motor 2 thermal model (%)
40608 ⁷	Power	0 to 11 12 to 13 14 to 15	power Power ratio Save
40609	Power factor percentage	0 to 7 8 to 15	100% = power factor 1 Save
40610	Voltage	0 to 13 14 to 15	Average root mean square voltage of all three phases Save
40611 ²	Current	0 to 13 14 to 15	Phase 1 current (root mean square value) Save
40612 ²	Current	0 to 13 14 to 15	Phase 2 current (root mean square value) Save
40613 ²	Current	0 to 13 14 to 15	Phase 3 current (root mean square value) Save
40614	Voltage	0 to 13 14 to 15	Phase 1 voltage (root mean square value) Save

Register	Explanation	Bit	Details
40615	Voltage	0 to 13 14 to 15	Phase 2 voltage (root mean square value) Save
40616	Voltage	0 to 9 14 to 15	Phase 3 voltage (root mean square value) Save
40617	Parameter list version	0 to 7 8 to 15	Parameter list minor revision number Parameter list major version
40618	Digital input status	0 to 15	For all inputs: 0 = open, 1 = closed (short circuit) 0 = start 1 = stop 2 = reset 3 = input A 4 = Input B 5 = Enter C (if installed) 6 = Enter D (if installed) 7 to 15 = reserved
40619~ 40631	Save		Save

1. Before using this function, make sure that the programmable input is not set to the motor group selection.
2. For 7000-53B and lower power models, this value is 10 times the value displayed on the operation panel.
4. Refer to the relevant soft starter manual for a complete list of parameters. The first product parameter is always assigned to register 40009. The last product parameter is assigned to register 40XXX, where XXX = 008 plus the total number of product available parameters.
5. Reading register 40603 (modified parameter value) will reset register 40602 (modified parameter number) and 40604 (Parameters have been changed). Always read registers 40602 and 40604 before reading register 40603.
6. Bits 10 to 15 of register 40604 report the soft starter trip or warning code. If the value of bits 0 to 4 is 6, the soft starter has tripped. If bit 5 = 1, the warning is activated and the starter continues to run.
7. The power ratio is as follows:
 - 0 = power multiplied by 10 to get wattage
 - 1 = power multiplied by 100 to get wattage
 - 2 = power (kW)
 - 3 = power multiplied by 10 to get kilowatts

13.5 Trip code

Trip code	Explanation	SCKR7000
1	Starting time limit	●
2	Motor overload (thermal model)	●
3	Motor thermistor	●
4	Current imbalance	●
5	Frequency (power)	●
6	Phase sequence	●
7	Instantaneous overcurrent	●
8	Power down / power circuit	●
9	Undercurrent	●
10	Radiator (starter) overheated	●
11	Motor connection	●
12	Input A Trip / Auxiliary Trip A	●
13	Rated current is too high / rated current is out of range	●
14	Unsupported option (triangle connection method does not support this function)	●
15	Starter communication (between interface and soft starter)	●
16	Network communication (between interface and network)	●
17	Internal fault X (where x is the fault code detailed in the table below)	●
20	Ground Fault	●
23	Parameter out of range	●
24	Input B Trip / Auxiliary Trip B	●
25	Bypass fault (bypass contactor)	●
26	L1 phase loss	●
27	L2 phase loss	●
28	L3 phase loss	●
29	L1-T1 short circuit	●
30	L2-T2 short circuit	●
31	L3-T3 short circuit	●
32	Motor 2 overload (thermal model))	●
33	Time overcurrent (bypass overload)	●

Trip code	Explanation	SCKR7000			
34	Thyristor overheating			●	
35	Battery / Clock			●	
36	Thermistor circuit			●	
37	RTD A is too hot			●	
38	RTD B is too hot			●	
39	RTD C overheating			●	
40	RTD D overheating			●	
41	RTD E overheating			●	
42	RTD F overheating			●	
43	RTD G overheating			●	
45	RTD circuit failure			●	
46	Analog input trip			●	●
255	Without tripping	●	●	●	●

1.Can only be used with SCKR7000 after installing suitable accessories.

2.For SCKR7000, only the built-in bypass model has time-limit overcurrent protection.

13.6 Internal failure x

The following table details the fault codes associated with trip code 17.

Internal failure	Messages displayed on the operation panel
70 ~ 72	Current reading error LX
73	Attention (A) Turn off the main power
74 ~ 76	Motor connection TX
77 ~ 79	Trigger failed PX
80 ~ 82	VZC fault PX
83	Low control voltage
84 ~ 98	Internal fault X Contact your local supplier for the meaning of fault code (X).

13.7 Examples

Command: Start

News	Starter address	Function code	Resgiter address	Date	CRC
Input	20	06	40002	1	CRC1~CRC2
Output	20	06	01	1	CRC1~CRC2

Starter status: running

News	Starter address	Function code	Resgiter address	Date	CRC
Input	20	03	40003	1	CRC1~CRC2
Output	20	03	2	xxxx0011	CRC1~CRC2

Trip code: Motor has passed

News	Starter address	Function code	Resgiter address	Date	CRC
Input	20	03	40004	1	CRC1~CRC2
Output	20	03	3	00000010	CRC1~CRC2

Load · Number (parameter 1A)

News	Starter address	Function code	Resgiter address	Date	CRC
Input	20	03	40009	1	CRC1~CRC2
Output	20	03	03	600	CRC1~CRC2

Write parameter Stop mode (parameter 2H), setting = 10

News	Starter address	Function code	Resgiter address	Date	CRC
Input	20	06	40020	10	CRC1~CRC2
Output	20	06	19	10	CRC1~CRC2

13.8 Modbus error code

Code	Explanation	Examples
01	Illegal function code	Functions other than 03 or 06
02	Illegal data address	Invalid register number
03	Unreadable data	Register does not allow data reading
04	Unwritable data	Register does not allow data to be written
05	Data boundary error	Multiple data transfers through data boundaries, or data size greater than 125
06	Command code is invalid	For example, write 6 to register 40003
07	Illegal parameter read	Parameter number is invalid
08	Illegal parameter write	Parameter number is invalid, read-only or hidden parameter

13.9 Modbus control via remote control

The Modbus interface can be used to connect the remote control to the soft starter and enable control via the RS-485 serial communication network. For details, refer to the remote control instructions. Modbus

13.10 Grounding and shielding

It is recommended to use a data shielded twisted pair cable with a ground shield. The two ends of the cable shielding layer should be connected to a point of the grounding device terminal and the field protection ground wire.

13.10 Termination resistor

On long cables that are susceptible to large noise interference, terminating resistors should be installed between the data lines at both ends of the RS-485 cable

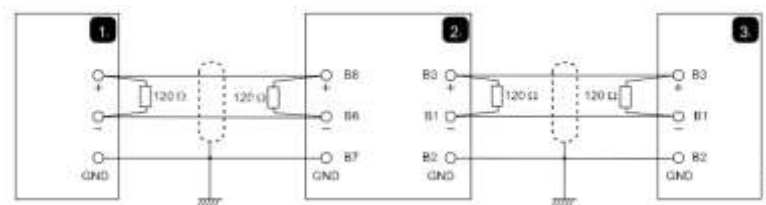

This resistance should match the impedance of the cable (usually 120Ω). Do not use wire wound resistors.

1	Network master device RS-485
2	Remote control RS-485
3	Soft starter RS-485

13.11 RS-485 Data cable connection

It is recommended to use daisy chain connection. The data cable is connected in parallel to the actual device terminals to achieve this connection.

13.12 RS-485 network connection specification of remote control

Input impedance: $12\text{k}\Omega$

Common mode voltage range: -7V to $+12\text{V}$

Input sensitivity: $\pm 200\text{mV}$

Minimum differential output voltage: 1.5V (maximum load is 54Ω)

STAR KING TECH 鑫擎科技

NINGBO STARKING TECHNOLOG CO.,LTD

Address: No.188,Jinghua Road,High Tech District,Ningbo,Zhejiang

Mobile:0086-15306616793

Email:cindy@starking-tech.com

Http://www.starking-tech.com

